

6086

 **TRIO**

**ALL BAND
SSB TRANSCEIVER**

TS-510



OPERATING MANUAL



ALL BAND SSB TRANSCEIVER TS-510

CONTENTS



Special Features	2
Circuit Description	3
Controls and their Functions	11
Operating Instructions	15
Accessory Circuitry	20
Alignment and Maintenance	22
Specifications	29
Schematic Diagram	30
Product Guide	31

Thank you for purchasing a **TS-510 ALL-BAND TRANSCEIVER**. The transceiver you have just purchased has passed all of our quality control tests; however, if it is found to be damaged or actual performance does not meet that specified due to accidents during shipment, please feel free to contact your local dealer.

SPECIAL FEATURES

1. The TS-510 is a high power, high stability SSB transceiver representative of the SSB era.
2. The Gothic style cabinet design, which gained the admiration of all users of the earlier 500 Series, is employed and will doubtlessly add to the appearance of any shack.
3. The use of an extremely stable VFO, a new development built around 2 FET's and 13 transistors, insures stable QSO's as long as you operate.
4. Accurate, double-gear tuning mechanism and linear tuning capacitor provide 1 kHz direct reading on all bands.
5. Frequency coverage has been reduced to 25 kHz for one complete rotation of the dial to facilitate tuning in of SSB signals.
6. A high frequency filter especially developed for the 510 Series is employed. Its excellent shape factor makes sharp cutoff for both receive and transmission with the TS-510 possible.
7. Equipped with a selectivity switch for both SSB and CW modes. Insertion of a CW filter makes CW operation more pleasant. The CW filter is available as a optional item.
8. The AGC circuit includes an amplifier to insure such high performance that even the largest input signal can be received without distortion. The AGC circuit also features signal strength meter indication independent of RF gain adjustment.
9. Built-in calibration circuit. This circuit is a 25 kHz multivibrator which permits accurate calibration for every rotation of the dial, such as when making QSY's.
10. Equipped with a side-tone oscillator which eliminates the necessity of adding an RF oscillator for accurate CW reception.
11. Amplifier type ALC circuit employed has excellent ALC characteristics as compared to those of a grid detector. Beautiful SSB signals are produced without sputtering.
12. The ALC voltage can be observed on the meter to monitor operating levels for correct on-the-air operation.
13. Equipped with an RIT circuit which permits fine adjustment during reception and tuner reading correction without changing the main dial setting.
14. The receiver is a dual conversion superheterodyne in which the RF and local oscillator are independently tuned. This, together with the high performance high frequency filter and bandpass filter, provides high stability and sensitivity.
15. AGC time constant can be switched between SLOW and FAST.
16. The use of an external VFO (VFO-5D) in conjunction with the internal VFO permits still more elaborate operation highly regarded by old hands.
17. Many accessory circuits, such as VOX, PTT, amplifier type AGC, RIT, CAL circuits, bandwidth switching, multimeter which indicates Ip, RF, HV, ALC, and signal strength, AGC switch, terminals for external VFO, ALC, and receiver input and output terminals.
18. The power supply are independently and externally connected to the transceiver. The Model PS-510 (containing speaker) power supply unit is also available.

CIRCUIT DESCRIPTION

The TS-510 transceiver employs a high frequency crystal filter and covers all ham bands from 3.5 ~ 29.7 MHz. Both the receiver and transmitter sections employ the dual conversion configuration. The VFO is solid state and stable.

This transceiver employs printed circuit boards, almost all of which are independently built for individual sections. As shown in the circuit diagram on page 30, each printed circuit board has its own unit number with the resistors, capacitors, and coils having specific 3-digit numbers (see Table 1).

The numbers appearing in the following explanations are all based on this numbering scheme.

Fig. 1 is a block diagram of the TS-510 transceiver.

During transmission, the signals pass through the microphone, mic. amplifier, balanced modulator, buffer amplifier, crystal filter, IF amplifier (common to both receiver and transmitter sections), first mixer, BPF, second mixer, driver, power amplifier, and antenna. ALC is applied to the buffer and common IF amplifier. On the other hand, the received signals are fed through the antenna, RF amplifier, first mixer, BPF, second mixer, crystal filter, common IF amplifier, IF amplifier, ring detector AF amplifier, and speaker. AGC is applied to the two-stage IF amplifier and RF amplifier.

The TS-510 includes a carrier oscillator, VFO, heterodyne crystal oscillator, 25 kHz marker, and side-tone oscillator. Accessory amplifiers are the AGC, ALC, VOX, and relay amplifiers.

CIRCUITRY COMMON TO BOTH TRANSMITTER AND RECEIVER SECTIONS

1. MICROPHONE AMPLIFIER AND BALANCED MODULATOR (UC1501J)

AF signals fed through the microphone terminals pass through a low-pass filter to eliminate their unwanted high frequency components, supplied to the

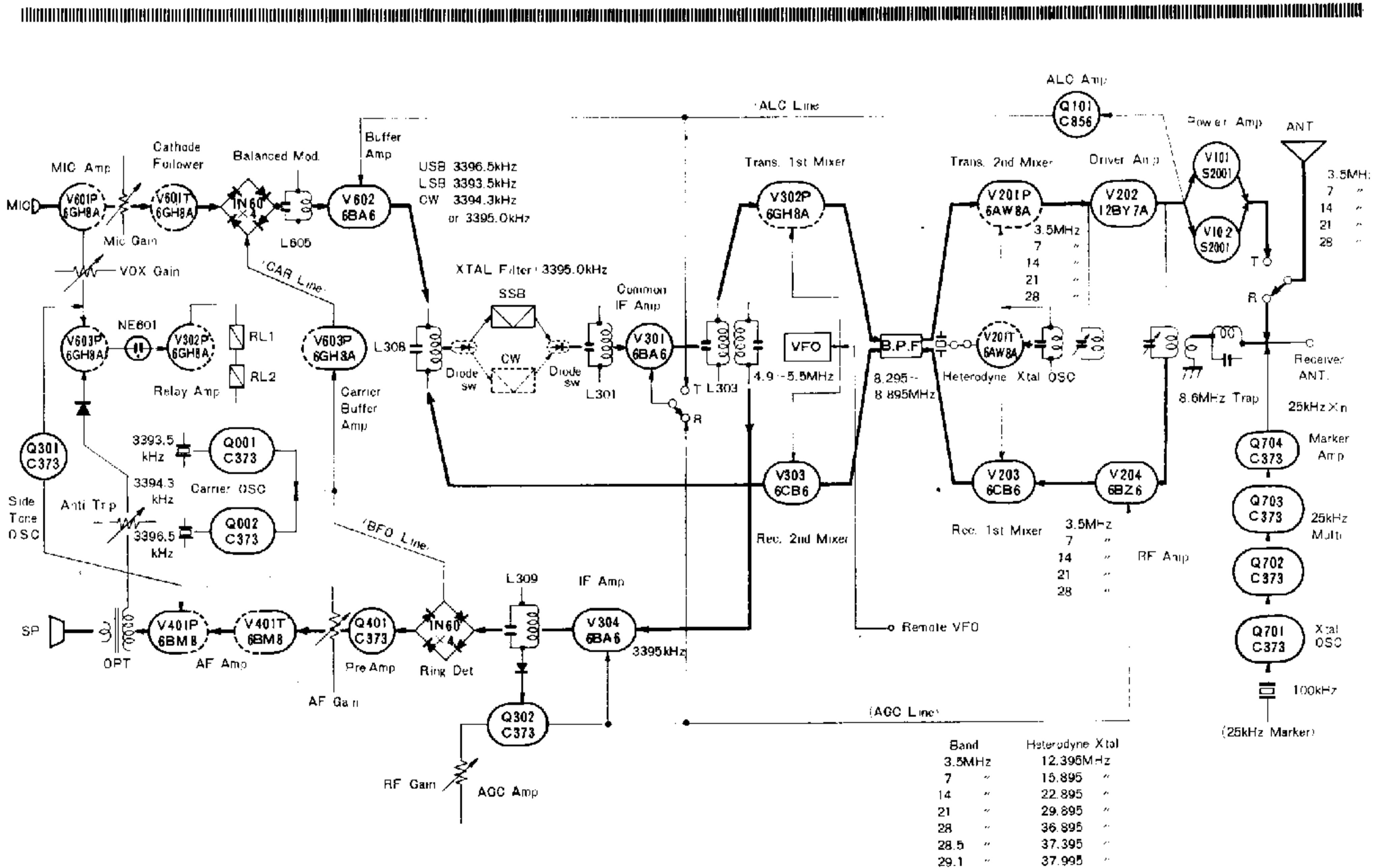

Fig. 1 Block Diagram

6GH8A (V601P), which amplifies the AF signals, and then fed through microphone gain potentiometer VR to the other section of the 6GH8A (V601T). This triode section is a cathode follower which converts the impedance of the AF signals before feeding them to the balanced modulator when the mode switch is set to either USB or LSB. In the CW mode, a DC voltage is produced across carrier level adjust potentiometer VR (VR601).

The input signals are then fed to the balanced modulator consisting of four diodes, which modulates the carrier with the AF signals (USB 3396.5 kHz; LSB 3393.5 kHz; CW 3394.3 kHz or 3395.0 kHz) to generate DSB signals across the secondary terminals of L605.

The carrier is passed through the switching circuit (6GH8A, V603T) and fed to the balanced modulator only during transmission. The 6GH8A also serves as a buffer.

2. CARRIER OSCILLATOR (UC1405J)

In general, SSB transceivers use the carrier oscillator as a BFO for reception (Fig. 2). The TS-510 employs the same technique. Therefore, the transmit carrier frequency and BFO frequency must be separated by the beat frequency when CW signals are received. In addition, it is also desirable to set the BFO frequency close to but out of the filter bandwidth, so that it can produce a single beat tone.

Table 1 Code numbers of units used in the TS-510

Name of unit and block		Unit No.	C & R code No.
Coil Pack	Drive plate	UC1108J	950~999
	Drive grid	UC1109J	900~949
	X'Tal tuner	UC1110J	850~899
	Crystals	UC1111J	800~849
RF block		UC1112J	200~299
IF block		UC1204J	300~399
Diode switch Unit		UC1209J	500~549
AF block		UC1304J	400~499
Final block		UC1404J	100~199
Carrier unit		UC1405J	001~099
BM block		UC1501J	600~699
Marker Unit		UC1502J	700~799
VFO Unit		UC0110J	—
Main Unit and others		—	1~99

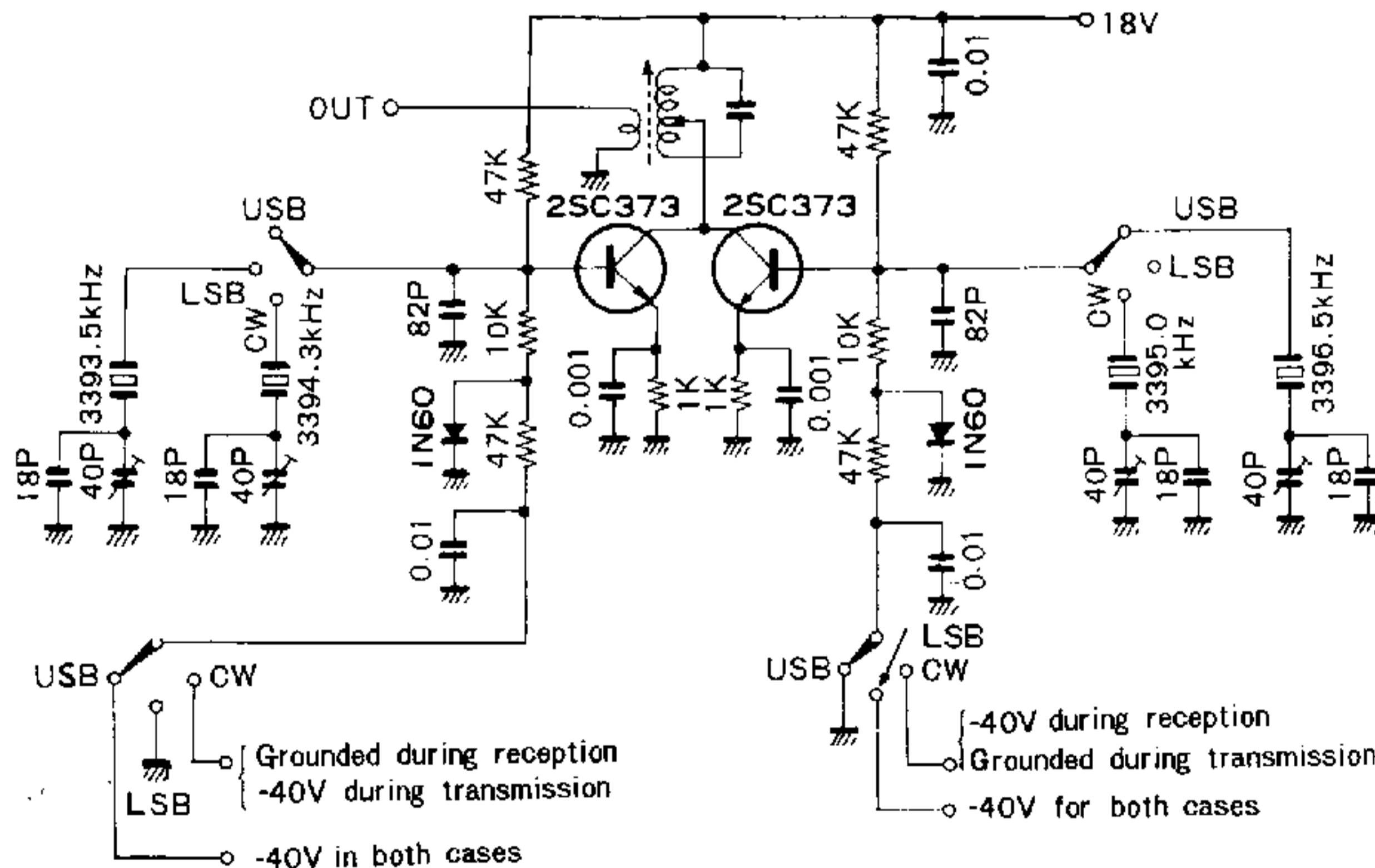

Fig. 2 Carrier oscillator (When the CW filter is equipped and four crystals are installed)

This makes it necessary to change the BFO frequency in accordance with the bandwidth of the filters when the filters are altered.

The TS-510 has a CW filter in addition to the SSB filter. Therefore, it is necessary to change both the carrier frequency and BFO frequency when the CW filter is used for CW operation, while they can remain the same when the SSB filter is used for CW operation. The carrier and BFO frequencies are shown in Fig. 3 each of these cases. Three carrier crystals are required for the SSB filter and four for the CW filter.

The carrier oscillator is a B-E Pierce with two transistors connected in parallel and switched to oscillate three or four crystals. The oscillation frequency of the individual crystals can be adjusted by means of the trimmer capacitor inserted between the crystals and ground.

3. BUFFER AMPLIFIER (UC1501J)

The DSB signal produced by the balanced modulator is amplified by the buffer amplifier 6BA6 (V602) and fed to the subsequent crystal filter. This amplifier operates during transmission with its being controlled by the ALC voltage.

4. DIODE SWITCH (UC1209J) AND CRYSTAL FILTER (UC1204J)

The DSB signal amplified by the buffer passes through L308, the diode switch unit, and the SSB filter where it is converted into an SSB signal (center frequency of 3395.0 kHz). After passing through the SSB filter, the SSB signal is passed through the diode switch at the output side and fed to L301. As shown in Fig. 4, this SSB filter has an excellent characteristic with a shape factor of less than 2.

The TS-510 can house both the SSB filter and a CW filter. A diode switch is provided to switch these two filters. In sets in which only the SSB filter is equipped, the diode switch is unnecessary and is therefore shunted with a jumper wire.

As shown in Fig. 5, the diode switch operates under the principle in which a forward voltage is applied to the two series diodes to turn them on and the voltage drop developed across the resistors at this time applied to the other diodes in the reverse direction to turn them off.

5. IF AMPLIFIER COMMON TO TRANSMITTER AND RECEIVER SECTIONS (UC1204J)

The SSB signal passing through L301 is amplified by the 6BA6 (V301). The output of V301 is then fed to the transmitter 1st mixer from the primary winding of L303 during transmission, or to the receiver IF amplifier from the secondary winding of L303 during reception.

This common IF amplifier operates during both reception and transmission. Its gain is controlled by the ALC and AGC voltages which cause the cathode voltage to change. This is utilized to operate both the bridge type ALC meter and the S-meter.

6. TRANSMIT 1ST MIXER AND BANDPASS FILTER (UC1204J)

The transmit 1st mixer receives the VFO signal (5100 ~ 4900 kHz) at the cathode of 6GH8A (V302), and the SSB signal at the control grid and through L303. The mixer converts the 1st IF frequency of the SSB signal (3395.0 kHz) into the 2nd IF frequency (8.895 ~ 8.295 kHz) does not change the mode of the signal.

The 3.4 MHz trap inserted in the plate circuit prevents passage of the 1st IF signal and the 14.13 MHz trap inserted in the cathode circuit prevents feedback of the output from the antenna. D302 in the cathode circuit is turned off during reception to prevent the 1st IF signal from passing to the receiver mixer through the VFO circuit.

After passing through the transmit 1st mixer the SSB signal is fed to the bandpass filter placed after L305. This bandpass filter (BPF) consists of three tuning circuits, has a center frequency of 8595 kHz and a passband of ± 300 kHz (-1 dB).

Unwanted components, such as spurious components, of SSB signal are eliminated by this BPF before the SSB signal is supplied to the transmit 2nd mixer.

7. VFO AND RIT (UC0110J)

This VFO (variable frequency oscillator) serves as a local oscillator whose signal is supplied to the transmit 1st mixer and the receive 2nd mixer. This is the block which determines the frequency stability and variable frequency range of receive and transmit signals of the TS-510. Therefore, special design consideration is given to insure high frequency stability over the entire range of frequency variation.

The VFO has an oscillation frequency range of 600 kHz between 5500 kHz (at 0 deg on the dial) and 4900 kHz (at 600). Solid state components are employed with the oscillator stage using an FET transistor to insure utmost frequency stability. The oscillator circuit used is a Clapp, followed by a one-stage voltage amplifier and two-stage buffer, which guarantees high stability under load fluctuations.

The VFO is completely sealed and all necessary adjustments are already made. Therefore, it is advisable not to open the cover or make any modifications of the exterior since they might result in reduced performance.

The RIT circuit is housed in the VFO box. An RIT voltage is applied from the outside to change the oscillation frequency of the VFO with the dial setting remaining the same.

The circuit to produce this RIT voltage is contained in UC1304J. The voltage can be controlled by RIT VR located on the front panel. (See Fig. 6).

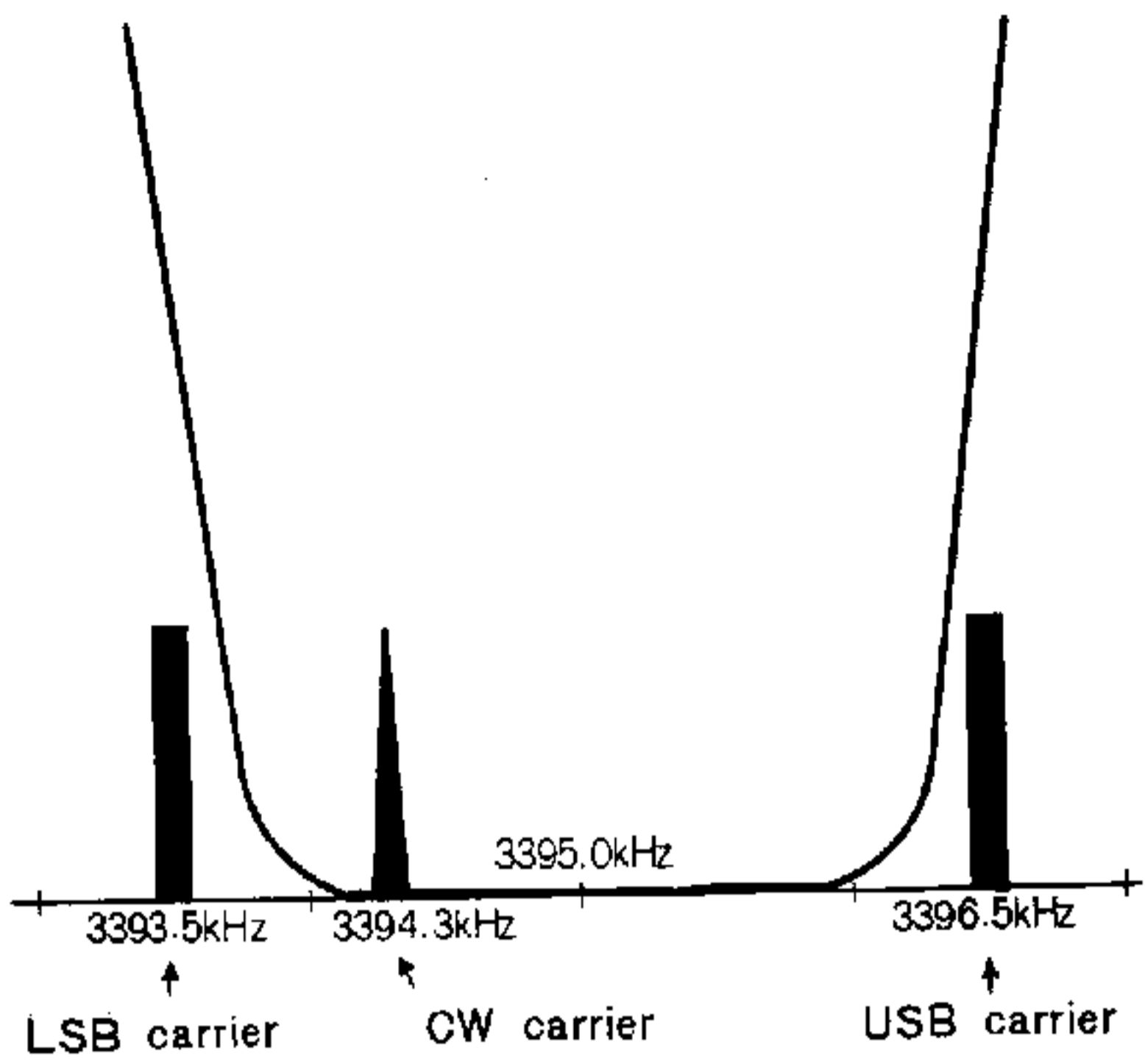

(a) In the case of the SSB filter only

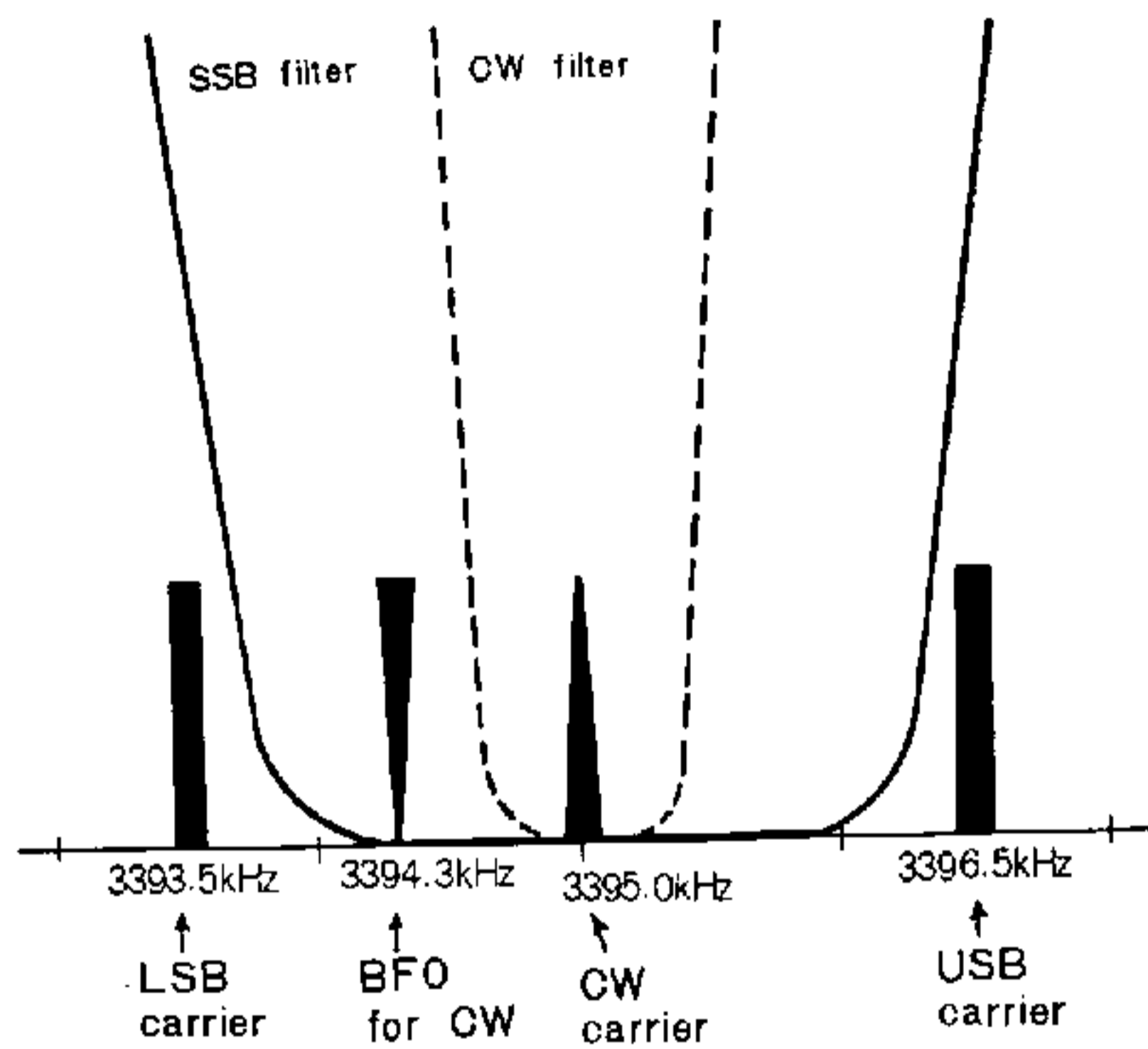

(b) When a CW filter is used

Fig. 3 Carrier and BFO Frequencies for Individual Modes

Attenuation (dB)

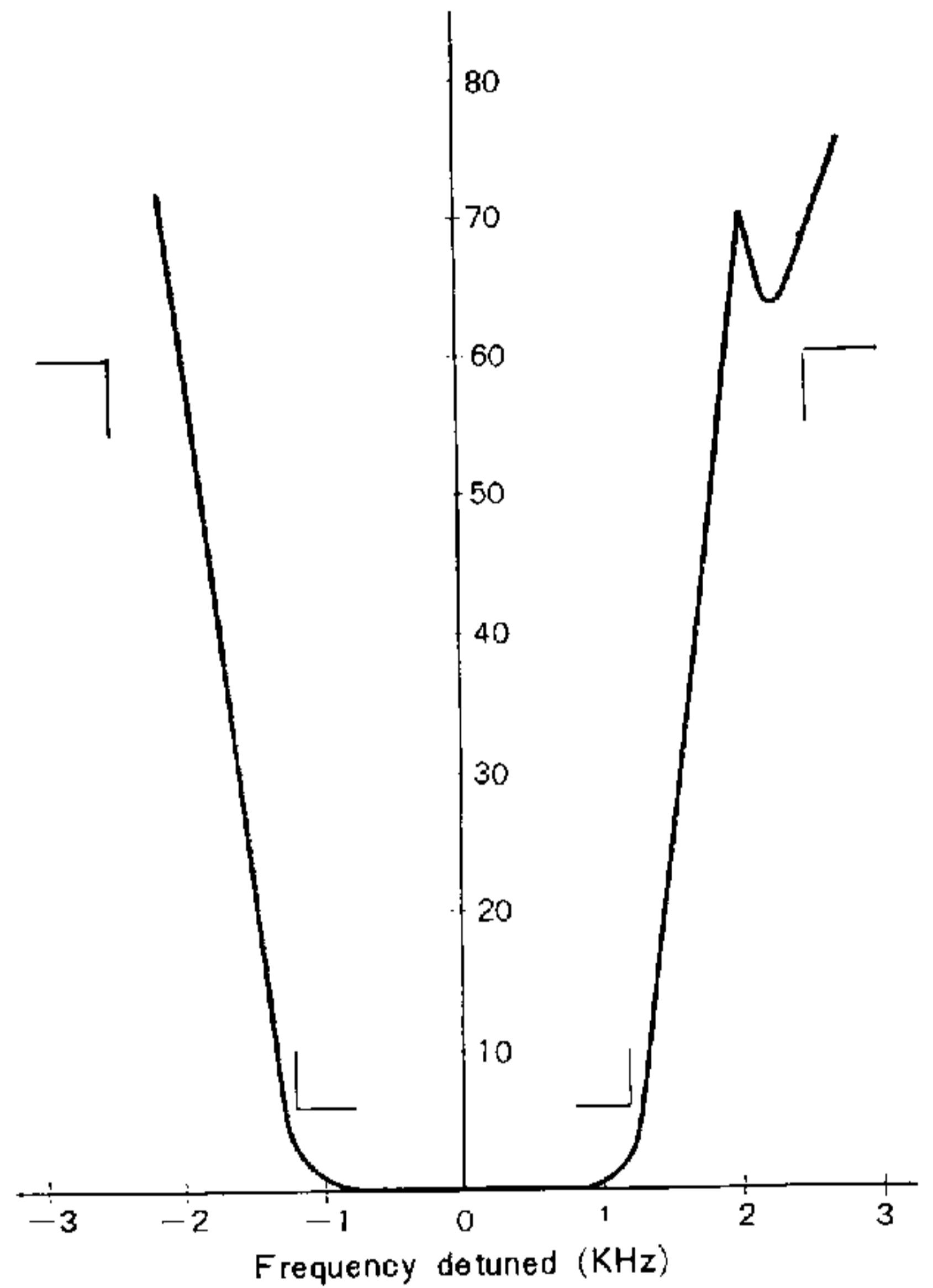

Fig. 4 SSB crystal filter characteristic curve

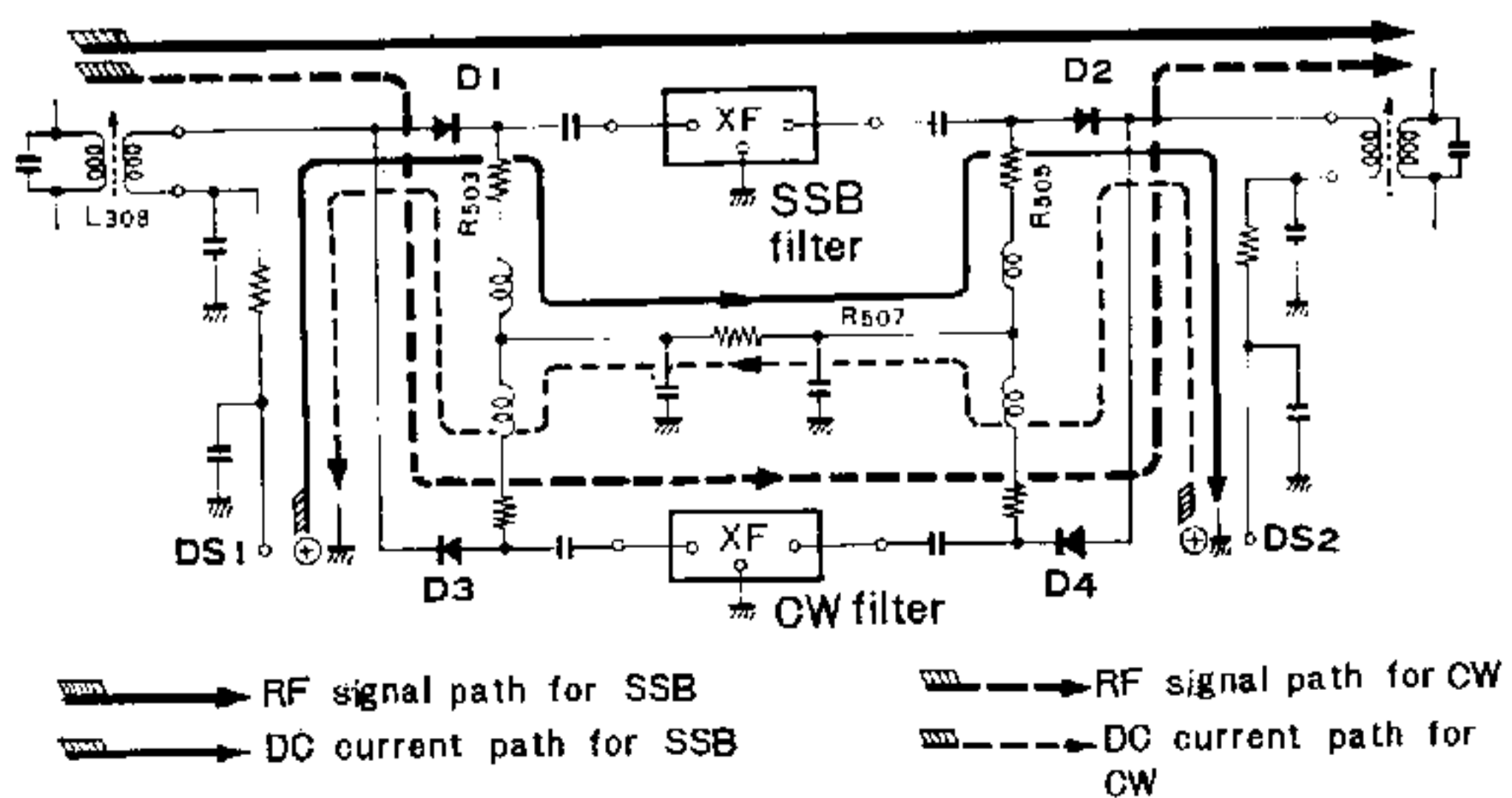

Fig. 5 Operation of diode switch

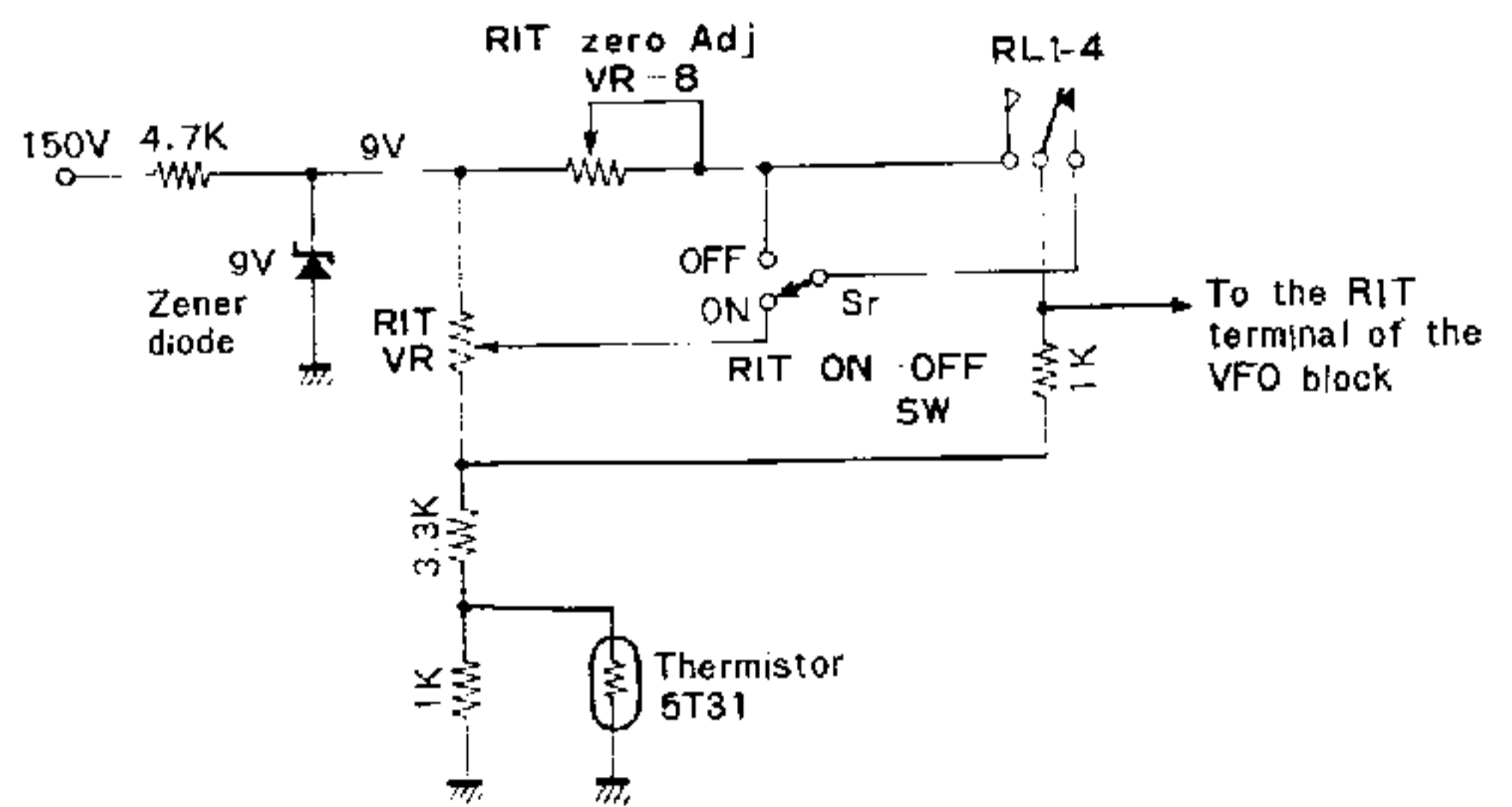

Fig. 6 RIT circuit

8. TRANSMIT 2ND MIXER (UC1112J)

After passing the BPF the SSB signal, which is now a 2nd IF frequency, is fed to the 6AW8A (V201P), mixed with the output of the heterodyne crystal oscillator injected at the grid, and converted into an SSB signal having a frequency within one of the amateur bands. The USB and LSB are inverted at this time, since the output is the heterodyne conversion difference frequency.

The plate tuning circuit (UC1109J) is a 3.5 MHz coil or a combination of another coil connected in series with the 3.5 MHz coil for the 7 MHz band and higher. The coils are designed so that the center frequency of the individual bands are tuned with the tuning capacitor half-meshed. These tuning circuits also serve as the RF tuning circuits during reception.

9. HETERODYNE OSCILLATOR (UC1112J), CRYSTAL UNIT (UC1111J), AND TUNING UNIT (UC1110J)

The local oscillation output is generated by these units and supplied to the transmit 2nd mixer and receive 1st mixer. All crystals operate on the third overtone and are switched by a rotary switch. The tuning coils are independent for the individual bands with the coil for the 28 MHz band divided into A, B, and C. The output is supplied to the transmit heterodyne mixer through coupling capacitors.

10. DRIVER AMPLIFIER (UC1112J)

The SSB signal converted into an amateur band frequency by the transmit 2nd mixer is fed to the 12BY7A (V202) and class A amplified to drive the final tubes (S2001 x 2).

The plate tuning circuit of this stage (UC1108J), is the same as that of the 2nd mixer and has independent tuning for the individual bands. The 3.5 MHz coil in this tuning circuit also includes an antenna link coil, since this tuning circuit serves as an antenna tuning circuit during reception. Since one end of this link coil is connected to the REC ANT terminals the driver output can be extracted from the REC ANT terminal if desired.

This driving stage and the transmit 2nd mixer are the section that the block bias keying for CW operation. Fig. 7 is a block bias keying circuit. This keying circuit permits the generation of a good keying waveform having a smooth rise and a reduced spece wave.

As shown in Fig. 7, V201P and V202 are controlled by TB line since the KEY line is grounded by the mode switch during SSB operation. For CW operation, both the KEY and TB lines are grounded and V201P and V202 operate to drive the S2001 tubes.

11. FINAL POWER AMPLIFIER AND ALC AMPLIFIER (UC1404J)

After being amplified by the driver stage the SSB signal is supplied to S2001 (V101 and V102) which linearly amplifies it and then feeds it to the π matching circuit and antenna.

The power amplifier consists of two S2001 tubes connected in parallel which operate in class AB1 with low distortion. The rated input power is 160W (CW). The S2001 tubes operate at an optimum of class AB1 when the base current is set to approximately 30 mA (plate current in the absence of an SSB signal). Bias voltage for this amount of current is approximately -45 V.

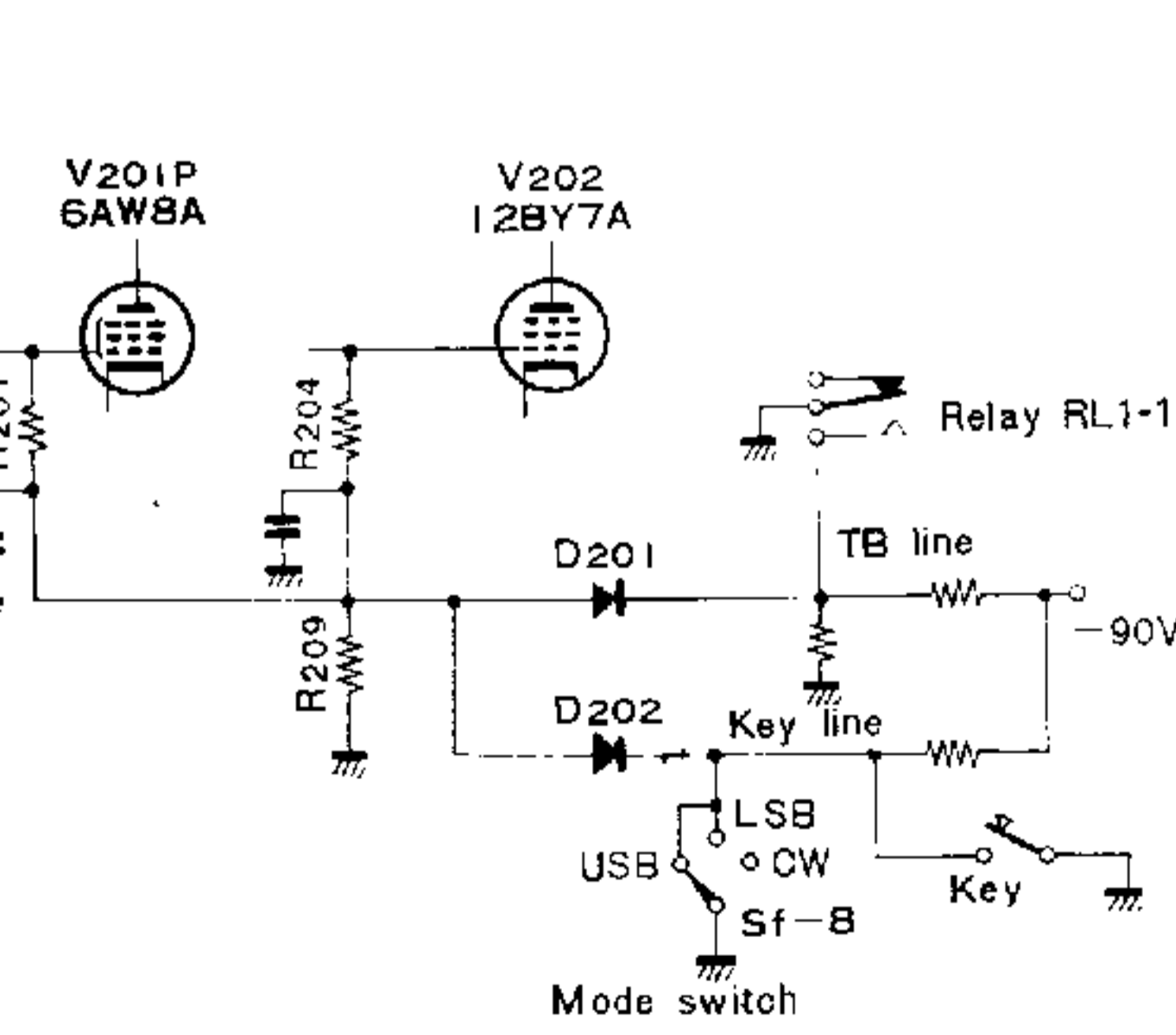

Fig. 7 Block bias keying circuit

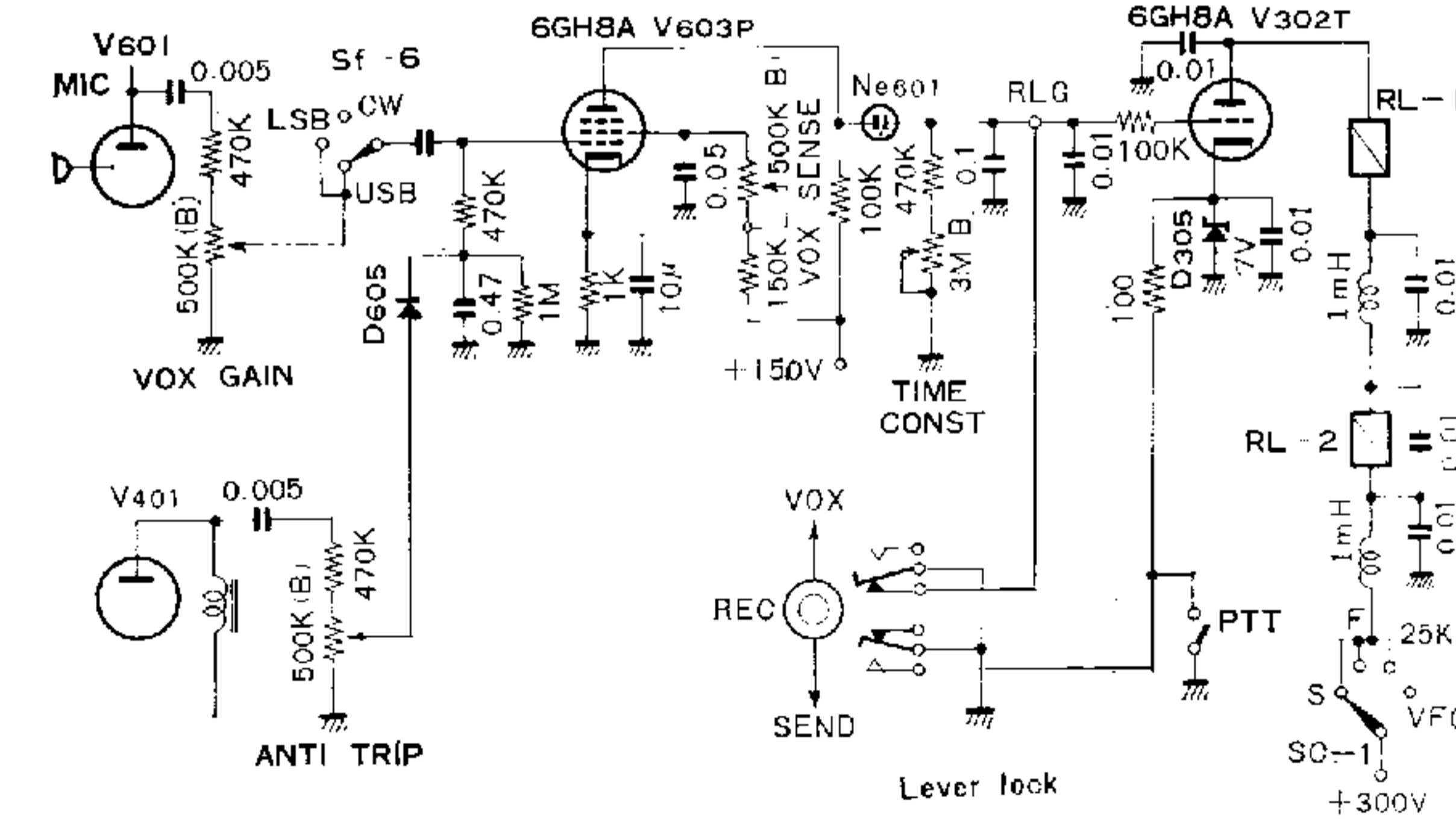

Fig. 8 VOX, anti-trip and relay amplifier

The capacitance of the π matching section at the antenna side is determined by the fixed capacitors and load variable capacitor selected by a switch for the individual bands so that it almost always matches the circuit to the antenna ($50 \sim 75 \Omega$) on any of the bands.

The ALC voltage is obtained by detecting the DC current flowing in the control grid of the S2001 tubes by 2SC856 (Q101) and amplifying it with the ALC amplifier. Therefore, this amplifier can follow intermittent grid current, such as that of CW, and insures the final amplifier linearity. The ALC time constant has a fast rise and slow decay. The time constant is also designed to be faster for CW than for SSB to facilitate tuning.

This ALC voltage is connected to the external exit terminal and, at the same time, supplied to the buffer amplifier and common IF amplifier to control their gains.

12. VOX AMPLIFIER AND ANTI-TRIP CIRCUIT (UC1501J)

The AF signal supplied through the microphone terminals is amplified by a one-stage microphone amplifier, passed through the VOX gain control, and fed to the 6GH8A (V603P), which amplifies the

signal and lights the neon tube (NE601). This circuit amplifies the side tone output instead of the microphone amplifier output when semi-break-in is made with the side tone. As the neon tube discharges, the plate voltage of V603 charges the time constant circuit of the VOX to produce a relay amplifier controlling voltage (refer to Fig. 8).

The screen grid voltage of the VOX amplifier is adjusted by the VOX. SENSE. VR (VR603) to a value at which the neon tube is about to discharge. The discharge time constant can be changed with the TIME. CONST. VR.

The anti-trip circuit receives the AF output from the AF final stage (UC1304J), diode rectifies it, and supplies a positive DC voltage to the grid of the VOX amplifier. This voltage causes the plate current of the VOX amplifier to increase and hence the plate voltage drop, which makes the neon tube less dischargeable.

13. RELAY AMPLIFIER (UC1204J)

The relay amplifier actuates two relays connected in series. The controlling operations of the relays are given in Table 2. One of their major functions is to switch the TS-510 between transmit and receive.

Other functions of the relay amplifier are to produce a voltage drop at the cathode of the 6GH8A (V302T) by means of the PTT and Lever Lock switch, and to apply the positive voltage of the VOX circuit to the grid to permit the plate current which actuates the relays to flow. When these controls are removed, the relays are automatically released by reduction of the plate current caused by the Zener diode inserted in the cathode circuit.

14. SIDE TONE OSCILLATOR (UC1204J)

This is an AF oscillator in which the 2SC373 (Q301) produces an oscillation output frequency of approximately 800 Hz. This output is supplied to the AF power amplifier tube (V401P) via VR to drive the speaker.

Since this circuit is used to monitor CW signals, the emitter, feedback circuit, and base voltage are controlled, and the circuit oscillates when the mode switch is set to CW (the emitter circuit is grounded), a key is inserted into the key jack (the feedback circuit operates), and when the key is depressed (base block bias is off).

RECIVER SECTION

1. RF AMPLIFIER AND RECEIVE 1ST MIXER (UC1112J)

The signal fed through the antenna terminal passes through the antenna tuning circuit (UC1108J) and enters the 6BZ6 (V204) RF amplifier. The signals amplified by this RF amplifier pass through the RF tuning circuit (UC1109J), and are fed to the 6CB6 (V203) receive 1st mixer built to be mixed with the output of the heterodyne crystal and converted into the 1st IF frequency ($8895 \sim 8295$ kHz).

Table 2 Relay Contact Allotment

RL 1-1	B M COM	RB (Receiver block bias) TB (Transmit block bias) GND
RL 1-2	B CM COM	RC (Receiver Cathode) TC (Transmit Cathode) GND
RL 1-3	B M COM	AGC ALC V301 grid circuit
RL 1-4	B M COM	RIT VR Fixed bias RIT terminal of VFO
RL 2-1	B M COM	} Refer to Fig 9 + terminal of the S-meter
RL 2-2	B M COM	} Refer to Fig 9 - terminal of the S-meter
RL 2-3	B M COM	REMOTE terminal GND
RL 2-4	B M COM	Receiver input Transmit output ANT terminal

B..... Break contact, M..... Make contact

The gain of the RF amplifier is controlled by the AGC voltage so that even the strongest input signal level does not cause any distortion. During transmission, the cathode of the RF amplifier is disconnected to apply blocking bias to the 1st mixer so that it has no affect on the transmitting stages.

2. RECEIVE 2ND MIXER (UC1204J)

The signal converted into the 1st IF frequency passed through the BPF and enters the receive 6CB6 (303 2nd mixer built. The signal is then mixed with the output of the VFO supplied at the cathode and converted into the receive 2nd IF frequency (3395.0 kHz). This stage is subjected to blocking bias during transmission.

3. IF AMPLIFIER (UC1204J)

After being converted into the 3395.0 kHz 2nd IF frequency, the signals pass through L308, the diode switch, the crystal filter, and enter's the common IF amplifier (V301). The gain of the common IF amplifier is controlled by the AGC voltage and the IF output is fed to the 6AB6 (V304) receive IF amplifier by the secondary winding of L303, passes through L309 and Ring detector, and enters the AGC circuit. The gain of the receive IF amplifier is controlled by the AGC voltage to maintain the a constant IF constant under fluctuations of antenna input level. The IF amplifier circuit does not operate during transmission since the cathode is opened.

4. AGC AMPLIFIER (UC1204J)

The AGC voltage is obtained by rectifying the signal developed across L309 by D304 and amplifying it with the 2SC373 (Q302) DC amplifier. This AGC amplifier produces an AGC voltage having an ideal time constant to permit quick starts and slow release since the impedance of the AGC source is made low by DC amplification and the impedance of the time

constant circuit is made high. Two SLOW and FAST time constants are available by switching AGC/CAL.

Since an RF GAIN VR is inserted in series with the AGC circuit, both manual and automatic gain control is simultaneously performed. This is the reason why the RF gain can be controlled without affecting the deflection of the S-meter.

5. RING DETECTOR (UC1501J)

After passing through L309, the IF signal is fed to the Ring detector consisting of four diodes which mixes the IF signal with the output of the carrier oscillator to convert it into an AF signal. The detector produces an AF output from the SSB signals with better fidelity as compared to a product detector.

6. AF AMPLIFIER (UC1304J)

The AF signals demodulated by the Ring detector are fed to the 2SC373 (Q401) preamplifier which amplifies it and supplies it to the AF GAIN VR. After passing through this potentiometer, the AF signal is voltage amplified by the 6BM8 (V401) tube and them power amplified before being fed to the earphone jack or speaker. The speaker impedance is 8 Ω (low impedance) and AF output is taken from the power supply type connector.

7. 25 kHz MARKER (UC1502J)

All the transistors used in this unit are 2SC373. Q701 oscillates the 100 kHz crystal, whose frequency can be adjusted with the trimmer capacitor (TC701) inserted in the collector circuit. This output serves to synchronize the multivibrator consisting of Q702 and Q703, which generates 25 kHz square waves.

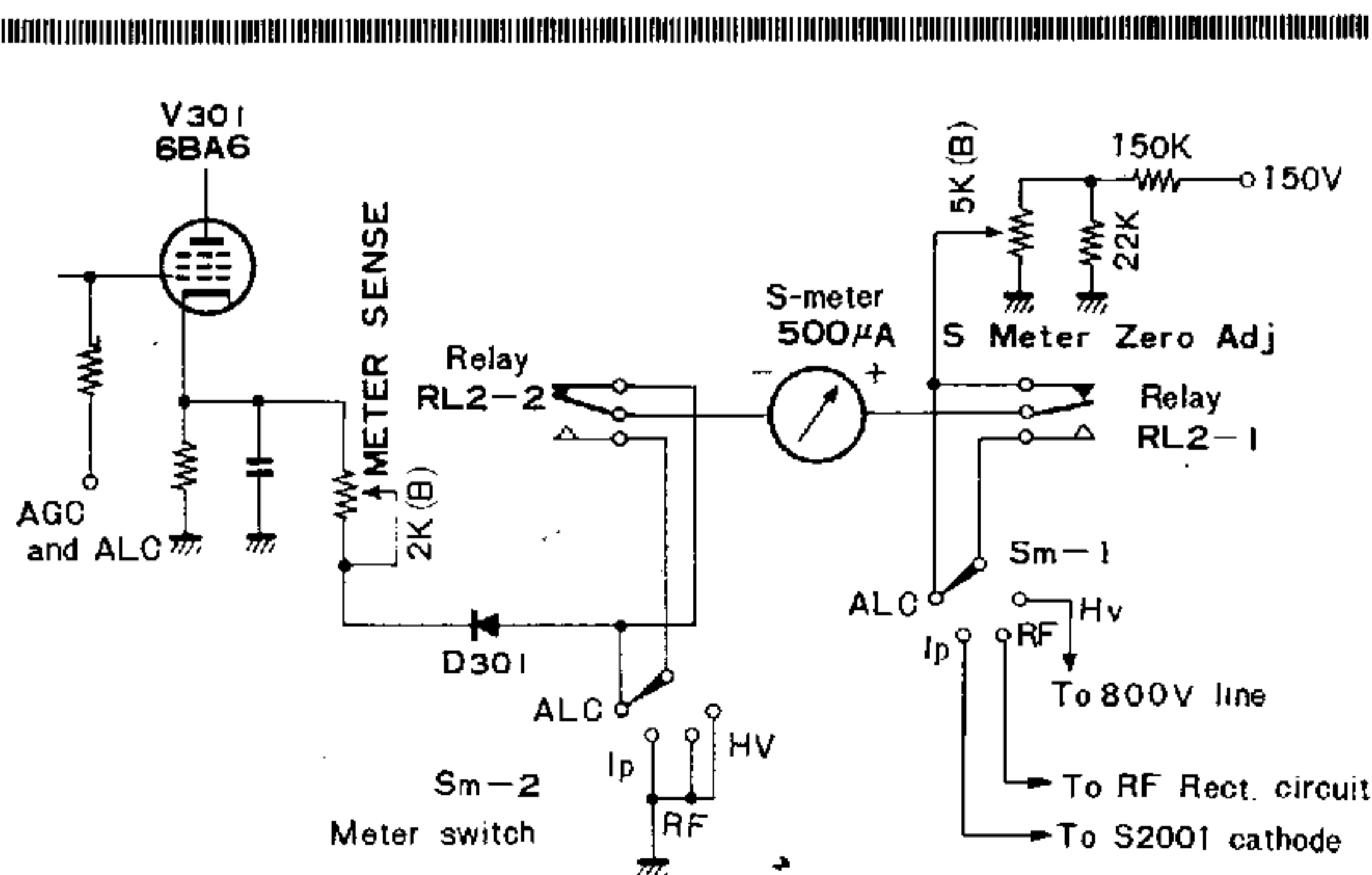

Fig. 9 Meter circuit

Table 3 Rotary Switch wiring

(a) MODE Switch

Sf-1	Switching of crystal (Q002)
Sf-2	Switching of Q002 Control biases
Sf-3	Switching of Q001 Control biases
Sf-4	Switching of crystal Q001
Sf-5	Switching of ALC time Constant
Sf-6	Switching of VOX
Sf-7	Switching of BM input
Sf-8	Shunting of the Key and side-tone
Sf-9	} Diode Switch
Sf-10	

(b) AGC/CAL Switch

Sc-1	Relay of OFF with VFO and CAL
Sc-2	AGC Speed Switching between SLOW and FAST
Sc-3	Beat detector circuit ON
Sc-4	Internal VFO and Marker Power Switch
Sc-5	Remote VFO power Switch

Although the oscillation frequency of the multivibrator can be changed by means of VR701, 25 kHz is obtained with the potentiometer position at approximately the center.

8. SPURIOUS BEAT DURING RECEPTION

The received signals are subjected to spurious beats at certain frequencies due to the relationship between the frequencies of the local oscillator.

The frequencies at which beat interference appears are,

3.5 MHz	3.7367 MHz (Within the band)
21.0 MHz	21.20 MHz (Within the band)

Interference at these frequencies is less than 3 dB. Although there is other spurious beat interference, they are less than 0 dB and do not cause any practical inconvenience.

■ OTHER CIRCUITS

1. HEATER CIRCUIT

The heater voltage is 12.6V. The 6.3V tubes used are divided into two groups connected in series. This configuration reduces the current capacity of the heater wires and eliminates the need for voltage balancing resistors which would otherwise be required.

2. METER CIRCUIT

Fig. 9 shows the meter circuit. The AGC and ALC are measured by reading the voltage at the cathode of a 6BA6 tube by means of a bridge circuit, I_p is measured in terms of voltage at the cathode of the 2S001 tubes. These are then displayed on the meter. The RF/HV voltmeter is used as an ordinary voltmeter.

The meter is designed to indicate signal strength during reception and ALC, I_p , RF, and HV during transmission. Switching between these indications is made by means of a relay circuit.

3. MAJOR ROTARY SWITCH CIRCUITS

Rotary switches include the band switch, mode switch, meter switch, and AGC/CAL switch. The operations of the mode switch, and AGC/CAL switch are listed in Table 3.

CONTROLS AND THEIR FUNCTIONS

FRONT PANEL (PHOTO 1)

(1) METER

This is a meter switch. With this switch set to ALC, the meter serves to monitor the driving conditions of the final power tube during transmission. With the switch set to Ip during transmission the meter indicates the plate current of the final power tube (to be more specific the cathode current). At position RF, the meter reads the RF voltage measured at the output terminal of the transmitter section. At position HV, the meter indicates the voltage at the plate of the final power tube during transmission.

This meter serves as an S-meter during reception regardless of the position of the meter switch.

(2) AGC/CAL

This switches between AGC and CAL. AGC (automatic gain control) can be made SLOW or FAST by selecting the time constant during reception. Set the AGC switch to the speed at which the received signals are most stable.

CAL is the calibration circuit, and switches between "25 kHz" and "VFO".

"25 kHz" is a 25 kHz marker whose frequency is produced by frequency dividing the 100 kHz of a crystal and using it to control a 25 kHz multivibrator. This marker is used to calibrate the main dial reading.

VFO is the calibrating circuit used to calibrate the internal VFO and remote VFO (VFO-5D) with each other.

(3) MIC

This is the microphone connector. Hook up a microphone with the accessory plug. Use a high impedance (50 K Ω) dynamic or crystal microphone.

(4) PHONES

This is a headphone jack. Its impedance is 8 Ω . A dynamic earphone with a low impedance is suitable, although a crystal type can be used.

When a plug is inserted in this jack, the speaker is cut off and the earphone connected in its place.

(5) MODE

This is used to change the mode of emission. Position USB enables reception of upper sideband signals and LSB lower sideband signals.

CW is for A1 signals and adjustment during transmission.

(6) MAIN DIAL

This is the main dial knob. Frequency coverage is 25 kHz per rotation. The flange of this dial is disengaged and idles when turned while being depressed toward the transparent scale plate. Calibrate the dial with the 25 kHz marker to make direct reading as fine as 500 Hz possible.

When the scale is disengaged by turning the knob, the dial cannot be rotated but stops at a certain point. Never attempt to turn it beyond this point. The gear teeth or other parts of the mechanism might otherwise be damaged.

(7) AF GAIN

This is the power switch and volume control. AC power is cut off at the extreme counterclockwise position and is switched on at all other positions. AF gain is increased by turning the knob to the right.

(8) PLATE LOAD

This is a dual knob. The inner knob is for adjusting the final power tube plate variable capacitor and the outer knob for turning the loading variable capacitor. This knob is used only for transmission and is not used during reception.

The upper scale corresponds to the plate knob and the lower scale to the loading knob on the panel. The impedance of the load decreases as the knob moves to the right.

(9) DRIVE

This knob serves for driver tuning during transmission and for ANT and RF tuning during reception. Adjust this knob so that a maximum driving power is obtained during transmission and maximum sensitivity is obtained during reception.

(10) RIT

RIT stands for "receiver incremental tuning" and is used to change the frequency during reception. It allows a frequency variation of approximately ± 3 kHz without using the main dial.

(11) RF GAIN RIT PULL OFF

This controls both receive sensitivity and switching of RIT between ON and OFF.

The RF gain is normally set to the extreme clockwise position (sensitivity maximum). However, it may be turned back to the left when the incoming signal is too strong. When this potentiometer is turned to the left, the deflection of the S-meter pointer increases from the zero point at which the pointer indicates in the absence of signals. This indicates that the receiver sensitivity decreases for signals with strengths below the point at which the meter pointer is set by the RF GAIN knob.

(12) BAND

This is the band switch. It divides the amateur channel from 3.5 MHz - 29.7 MHz into seven bands.

(13) LEVER LOCK SWITCH

This is the standby switch. When set to neutral (REC), it switches the transceiver to receive; when set to (SEND), it switches the set to transmission.

When shifted up, it establishes the circuit for VOX control.

When operating the TS-510 by PTT (push to talk), set the switch to REC.

(14) METER

This multimeter serves as an S-meter when the transceiver is at reception regardless of the position of the METER switch in (1).

For transmission, on the other hand, the meter displays Ip, RF, HV, or ALC, in accordance with the setting of the meter switch.

(15) DIAL GAUGE

The transparent plate has three lines on it. The central red line is for CW, the left side black line for LSB, and the right side black one for USB.

These three lines, USB, CW, and LSB, are aligned at 1.5 kHz intervals. For more accurate reading of frequencies, use the main dial mentioned in (6).

(16) AUXILIARY DIAL

This dial is turned by turning the main dial (6) and disc scale.

It is scaled at 25 kHz intervals and is used to read frequencies in larger than 25 kHz units while the main dial serves to show frequencies in finer units. Black graduations are 0, 50, and 100 kHz. Red graduations are 25 and 75 kHz.

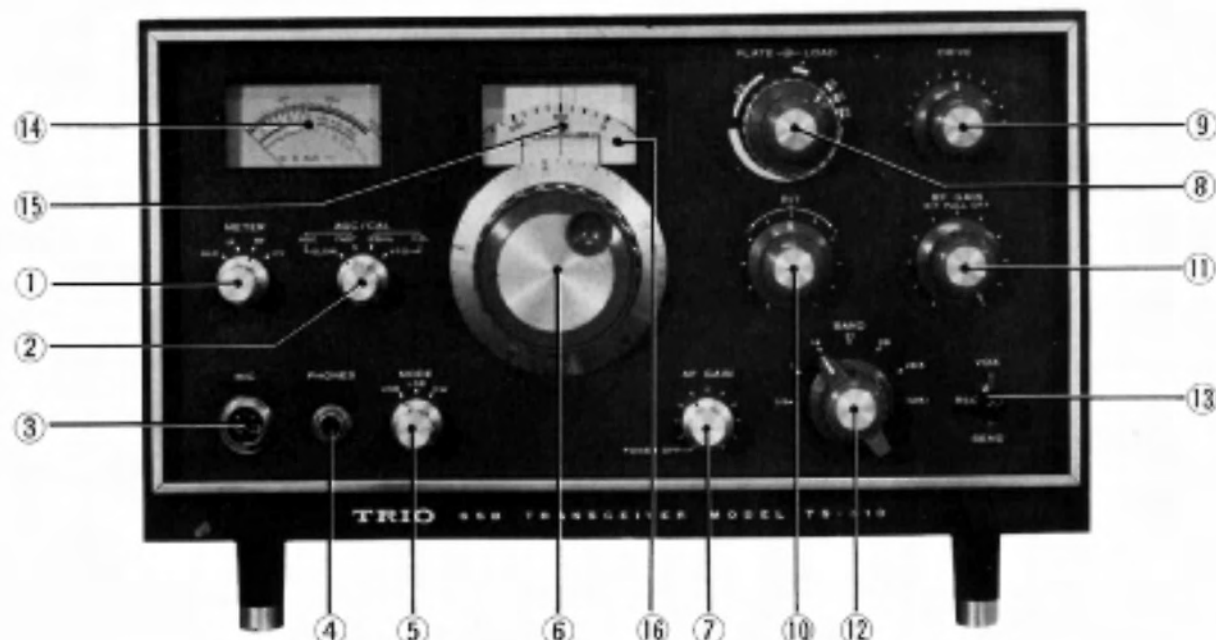

Photo 1 TS-510 Front Panel

REAR PANEL (PHOTO 2)

(1) BIAS

This controls the bias of the transmitter's final power amplifier. Adjust it for a plate current of 60 mA under no signal conditions in the USB or LSB transmission mode.

(2) KEY

This jack accepts a keying plug for CW operation. A plug is provided as an accessory.

(3) ANT

Antenna connections should be made here. Be sure to connect an antenna or dummy load before the transceiver is used. Impedance is 50 ~ 70 Ω .

(4) RF METER

This controls RF meter swing level. Adjust it so that the meter does not swing off the scale even at peak RF power with the METER knob on the front panel set to transmission.

(5) ANT SW (COM-REC)

This switches the antenna so that it can be used for both transmission and reception, or for both. Set

the switch to COM for dual use and set it to REC to use the antenna exclusively for transmission. In this case, the receive antenna should be connected to the REC ANT terminal to be explained below.

This switch is useful when a preselector is used in conjunction with the TS-510, since the transmitter and receiver sections can be connected through independent terminals.

(6) REC ANT

This terminal is used exclusively for reception. In normal operation, ANT terminal (3) serves for both reception and transmission and this antenna is therefore not required.

(7) VFO OUT

This connector is provided for the connection of an external VFO. All connections necessary to operate an external VFO, such as for the control circuit, power supply, and output of the VFO can be made through this connection. The connection cable is equipped on the external VFO and this connector is shunted by a shunt plug.

(8) GND

This is the grounding terminal. It is recommended that a good ground be connected here to prevent TVI and BCI, as well as for safety's sake.

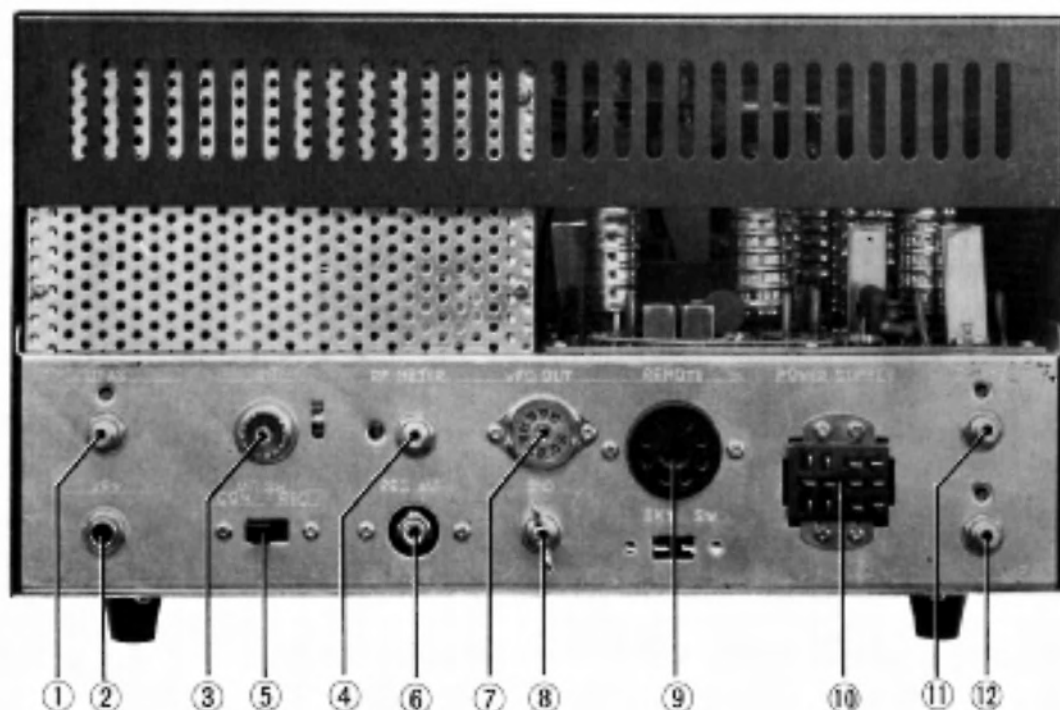

Photo 2 Rear Panel

(9) REMOTE

This terminal is provided for connection of such auxiliary as a linear amplifier.

(10) POWER SUPPLY

This is the power supply connection jack. It has a stopper which prevents the removal of the power cord during use.

(11) S METER

This enables zero adjustment of the S-meter. It should be adjusted to "O" under no receiver signal conditions.

(12) MIC GAIN

This is adjusted to control microphone output. Keeping this control at a the point that just provides sufficient modulation will prevent overdriving.

(2) ANTI-TRIP

This is for anti-trip adjustment. It should be set so that speaker response during VOX operation in the receiving mode will not accidentally trip the relay to the transmission mode.

(3) TIME CONSTANT

This controls the time constant of the VOX relay. Turn it clockwise to increase the time constant.

UPPER CHASSIS CONTROLS (PHOTO 3)

(1) VOX GAIN

This adjusts VOX sensitivity. In noisy surroundings it should be kept low.

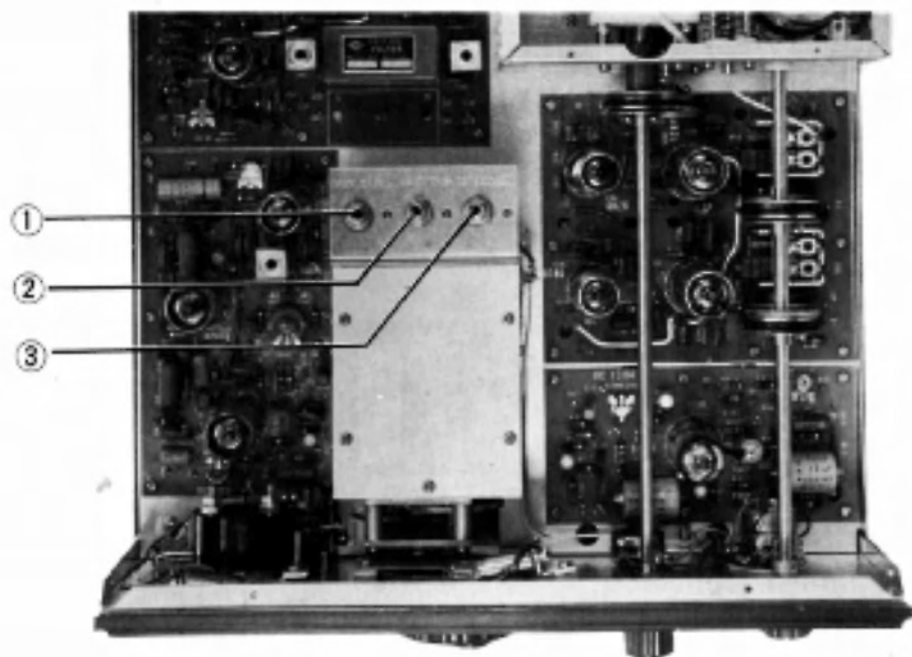

Photo 3 TS-510 Upper Chassis Controls

OPERATING INSTRUCTIONS

1. ACCESSORIES

The following accessories are supplied with this transceiver. Please check to see that all are provided.

M-type receptacle (for antenna connection)	1
4-pin metal plug (for microphone)	1
Receiver plug (for headphone and transmitting key)	2
9-pin plug (already plugged in)	1
US plug	1
Hyzex legs	2
Test rod	1

2. INSTALLATION LOCATION

Avoid high humidity locations when selecting the installation location. Choose a dry location which is free from direct sunlight. Maintain ample space at the back and sides of the transceiver. Also avoid placing objects on top of the transceiver.

3. POWER SUPPLY

This transceiver is not equipped with a built-in power supply and one must therefore be procured separately.

The Model PS-510 power supply is available for use with the TS-510. The source voltage rating is 230/250 V AC.

The PS-510 contains a 16 cm speaker provided with an accessory power cord, which is connected to the TS-510 to operate the power supply unit. Connections are shown in Fig. 10. The cord is 2 meters long.

4. ANTENNA

The quality of the antenna greatly affects the performance of the transceiver. The use of a good antenna high in the air with sharp directivity and rigid construction is recommended. It must also be noted that mismatching at high power will cause TVI and BCI. Therefore, perfect matching to the antenna is necessary.

The impedance of the antenna terminals of the TS-510 is 50 ~ 75 Ω . Thus, a 75 Ω coaxial cable from a doublet antenna can be directly connected to the terminals, while other Types of antennas must be properly matched with a coupler. (Refer to Fig. 11)

The TVI filter is available to help prevent such interference if any.

5. MICROPHONE

Since sound quality is considerably affected by microphone characteristics, a good microphone should be used.

A 50 K Ω dynamic microphone or crystal microphone, equipped with a switch, is recommended. Fig. 12 shows two types of switching arrangements ordinarily offered in microphones. Type (B) switching is suitable for PTT operation since, in this configuration, the switching circuit is independent of the microphone circuit, while in type (A) the microphone circuit is simply shorted.

The microphone cable should be connected as shown in Fig. 13. The cable is provided as an accessory.

6. PREPARATIONS PRIOR TO OPERATION

(1) Positioning the knobs

Connect the power supply, antenna (or a dummy load), and microphone, and set the knobs as follows. Do not attempt to adjust other controls until test operation is over, since they are already adjusted.

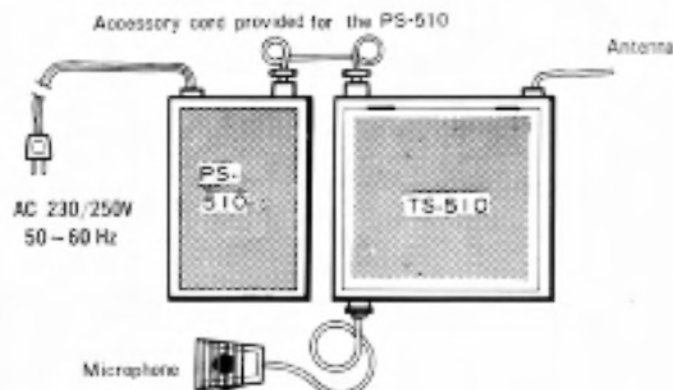

Fig. 10 TS-510 connections

METER — Ip

AGC/CAL — FAST

MODE — USB

PLATE — 21

LOAD — Set it to the extreme counterclockwise position.

DRIVE — Center

RIT — Center

RF GAIN — Set it to the extreme clockwise position.

RIT PULL OFF — Press the RF GAIN knob in the direction of the panel.

AF GAIN — Set it to the power-off position.

BAND — 21

LEVER LOCK SWITCH — Center (REC position)

DIAL — Set the main dial to the desired frequency.

Finally, check to see if the 9-pin miniature plug is firmly plugged into the connecting socket at the rear of the chassis. The VFO will not operate with this plug out.

(2) Reception

Turn the power on by turning the AF GAIN knob to the right. After the neon lamp of the power supply (PS-510) and the pilot lamp of the TS-510 light and the tubes are sufficiently warmed up, a faint internal operating noise can be heard from the speaker.

If an antenna is connected, incoming amateur stations will be received as the dial is slowly turned.

Adjust the DRIVE knob for increased sensitivity. Also check to see that the S-meter is deflecting in accordance with the strength of the received signal.

Reception and transmission of SSB radio signals are found at the lower sideband for frequencies of 7 MHz and below and at the upper sideband for 14 MHz and above. These are based on the international amateur communications agreements. Incorrect tuning will make it impossible to receive SSB stations.

(3) Transmission

Remove the antenna and connect a dummy load in its place. Leave the front panel setting as is (those that delivered maximum output of the signal under the reception test).

After allowing over 3 minutes warm-up from the moment the power switch was turned on, shift the lever lock switch from REC to SEND and confirm that Ip is 60 mA.

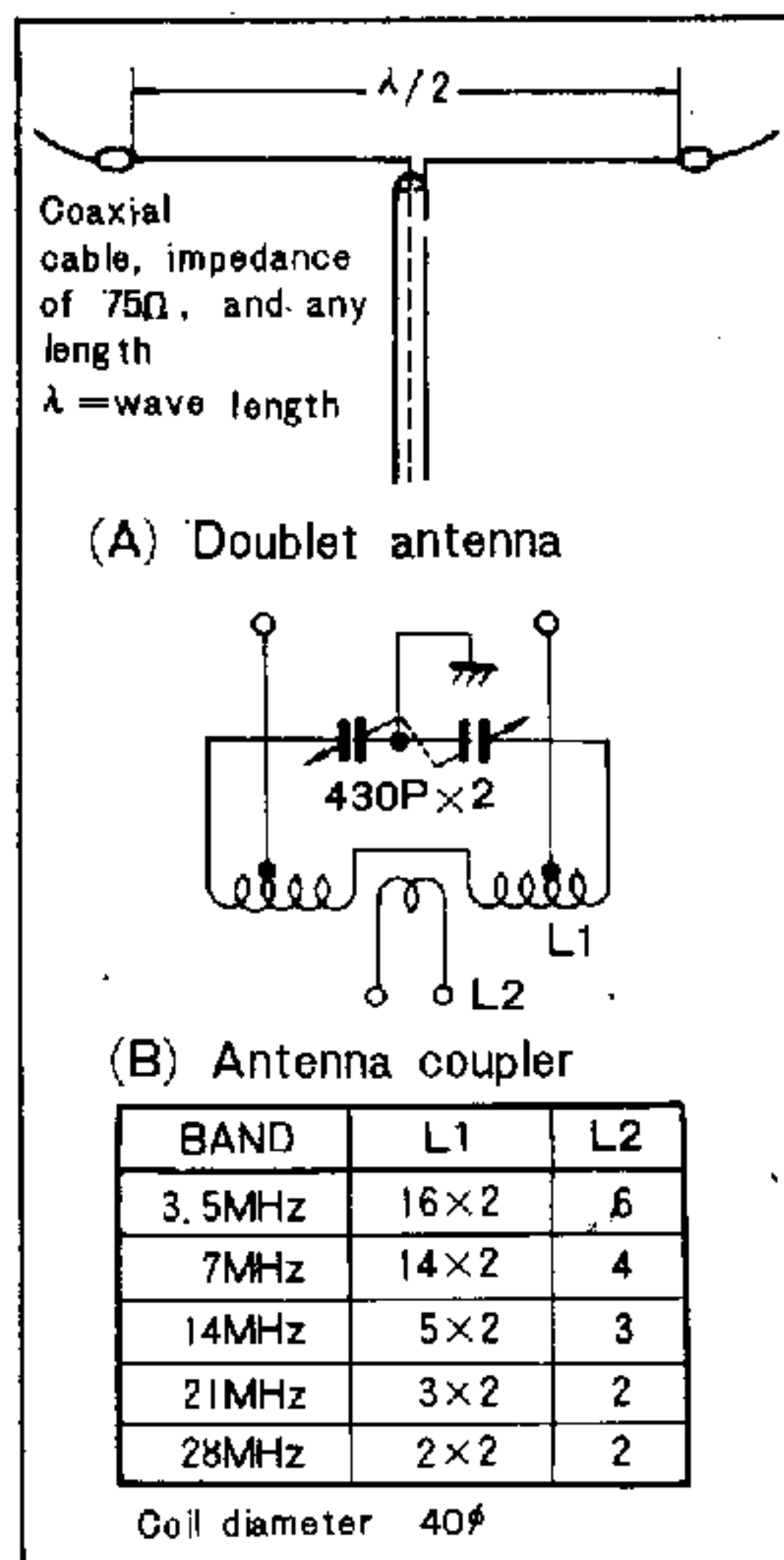

Fig. 11 Antenna coupler

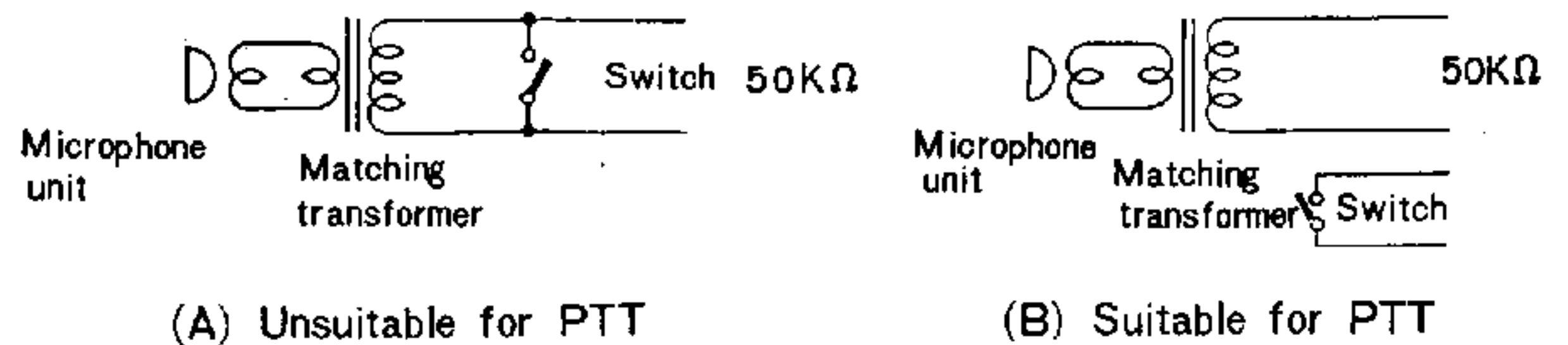

Fig. 12 Microphone with a switch

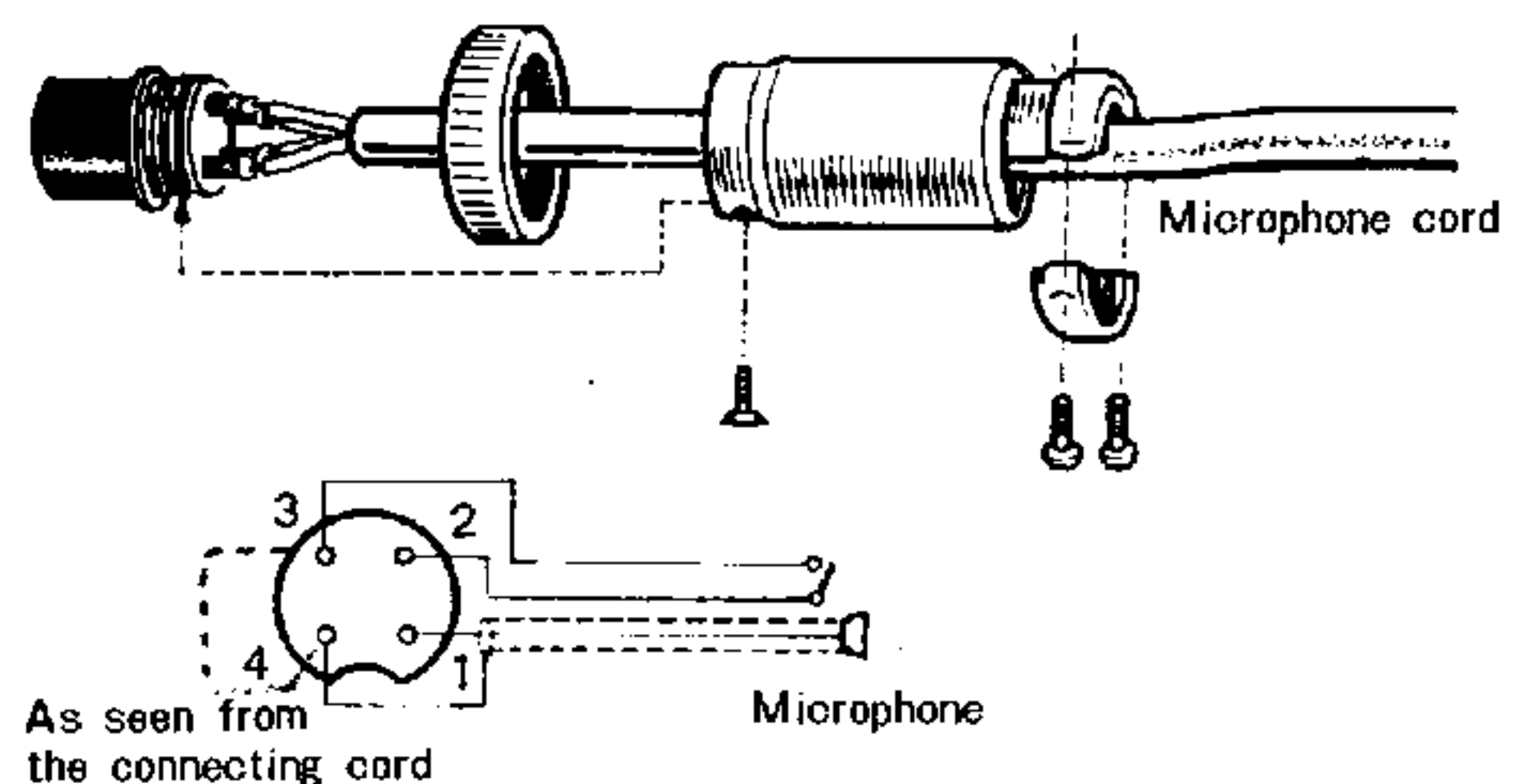

Fig. 13 Microphone cord connections

Switch the MODE from USB to CW. I_p may show a large increase. This indicates that the plate is considerably detuned and the a current as high as 250 mA will flow. If this is the case, quick correction is required by tuning the PLATE knob so that I_p meter deflection is minimum.

If the key is plugged in, there will be no I_p flow and no meter deflection unless the key is removed or depressed.

Now set METER to RF and tune DRIVE for maximum meter deflection. Adjust LOAD knob for further meter deflection. Adjustment of LOAD knob will cause the PLATE adjustment to shift. LOAD and PLATE should be adjusted alternately.

Finally, switch SEND-REC to REC and complete all preparatory adjustments.

These adjustment should be conducted quickly. Leaving the final power tubes (2S001) under full current conditions for more than 10 seconds might damage them. If it proves impossible to complete these adjustments within that period, reset the transceiver to reception and allow more than 10 seconds for the tubes to cool before any attempting adjustment.

7. HOW TO OPERATE THE TRANSCEIVER

Procedures necessary for operation are dealt with in this section. Therefore, simple adjustments are also covered to in this section.

(1) Input Level

Maximum plate current (I_p) for CW operation should be kept at 200 mA maximum. Further increases in I_p will result in damage of the S2001 tubes.

For SSB transmission, MIC GAIN located at the chassis rear should be retarded so that I_p is about 120 mA at its peak. Excessively large input causes distortion which interferes with other amateur communications.

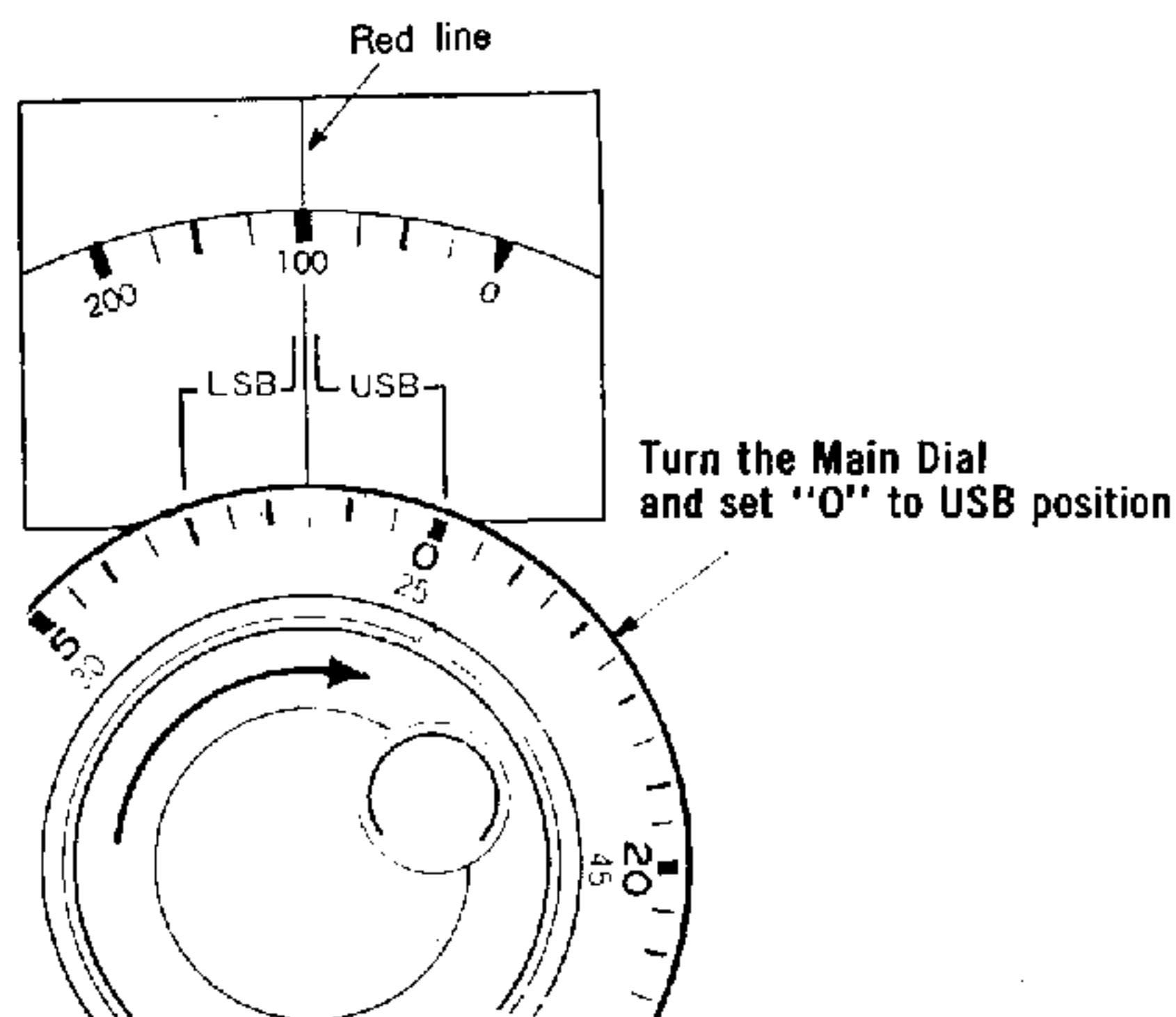

Fig. 14 To Calibrate when MODE switch is turned to the USB position

(2) RIT

When RIT is set to "O", the transmitting and receiving frequencies will be identical. Therefore, transmission can be made on the same frequency as the received signal and there is no need of calibration.

The RIT knob is used when it is desired to have a slight separation between the receiving and transmitting frequencies. RIT makes it possible to shift the receive frequency with the transmitting frequency unchanged. The variable range is approximately ± 3 kHz. Separations greater than this require an external VFO.

For example the associated station changes its transmitting frequency tracking it up with the main dial will cause the transmitting frequency of this transceiver to also change. By using the RIT for the change of the associated station, only the receive frequency can be changed with the transmit frequency unchanged.

The RIT knob will not function and the transmit and receive frequencies are automatically set to the same frequency by pulling out RF GAIN and RIT PULL OFF.

If the transmit and receive frequencies happen to become separated with RIT set to the correct position, conduct the following procedure for correction.

Set the RIT knob to "O" and receive the marker signal. Then open the top cover of the case and adjust RIT ZERO ADJ (VR402 10 K Ω) semifixed potentiometer while turning the RIT PULL OFF knob on and off so that beat produced from the marker signal can be heard at equal frequencies regardless of the setting of the RIT PULL OFF knob. The RIT ZERO ADJ knob is located at the upper right of the AF unit (UC1304J).

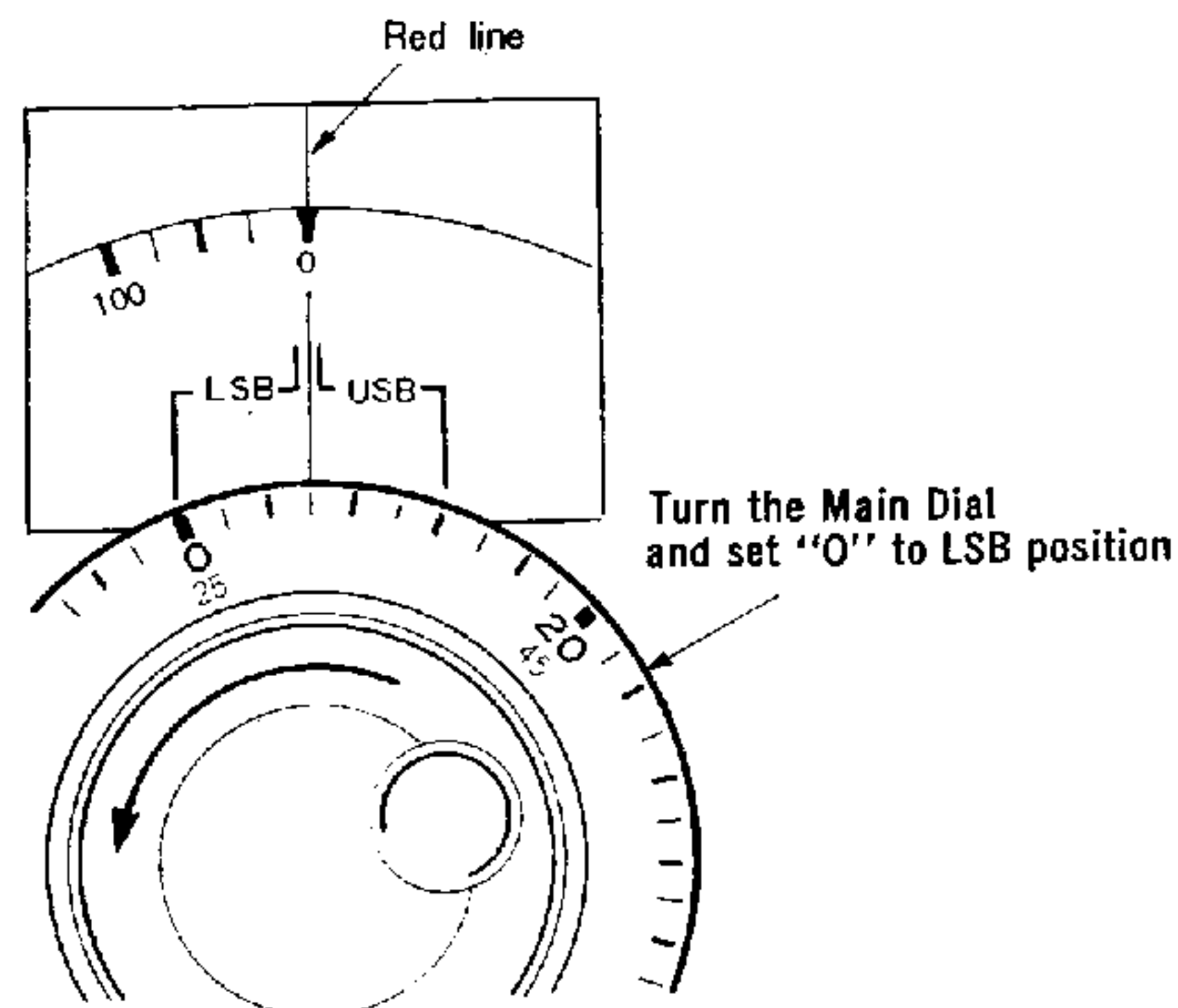

Fig. 15 To Calibrate when MODE switch is turned to the LSB position

(3) VOX

Voice-controlled automatic switching of the transmit and receive modes is possible with this transceiver when SEND-REC is switched from REC to VOX. VOX GAIN control at the top of the chassis should be retarded when the surrounding noise level is high. Changes in supply voltage may sometimes cause sluggish relay action. In such a case, modify the supply voltage to 230V or 250V.

A anti-trip circuit is built-in to prevent speaker response from tripping the relay, and switching the transceiver from the receiving to the transmitting mode. The ANTI-TRIP control located at the top of the chassis should be adjusted so that tripping will not occur. It is undesirable, however, to reduce VOX gain too much since this will result in unreliable tripping. Therefore, the microphone and speaker should be located away from each other and the speaker volume level be kept as low as possible.

TIME CONSTANT controls the discharge time constant of the VOX circuit and regulates the tripping frequency of the relay, which takes place during pauses between speech and vary from individual to individual. Therefore, adjust the time constant to a value which suits the operator. VOX sensitivity can be adjusted with semifixed potentiometer VR601 500 K Ω (VOX SENSE) located on printed circuit board UC1501J.

Use of a uni-directional microphone will make VOX operation even more reliable.

(4) Main Dial Calibration

Calibration of the main dial may be easily performed by setting the zero position of the main dial to the zero of the auxiliary dial plate. For more accuracy, however, the marker signal and calibrator can be used. In this case, set the AGC/CAL knob to 25 kHz and produce a beat with the marker signal. A beat will appear at different frequencies depending upon whether the transceiver is set to LSB or USB.

(a) When the MODE switch is set to USB

Turn the main dial knob clockwise while listening to the beat. The beat frequency will be high at first and then gradually decrease as the main dial is rotated until it become nil. Stop the dial at this zero beat point and set the zero position of the main dial scale to the USB pointer. (Refer Fig. 14)

(b) When the MODE switch is set to LSB

Turn the main dial counterclockwise or the reverse of USB. The beat is similarly high at the beginning, decreases as the dial is turned, and eventually becomes zero.

Calibration procedure is identical to that of USB except that the dial should be set to the LSB pointer (Refer to Fig. 15).

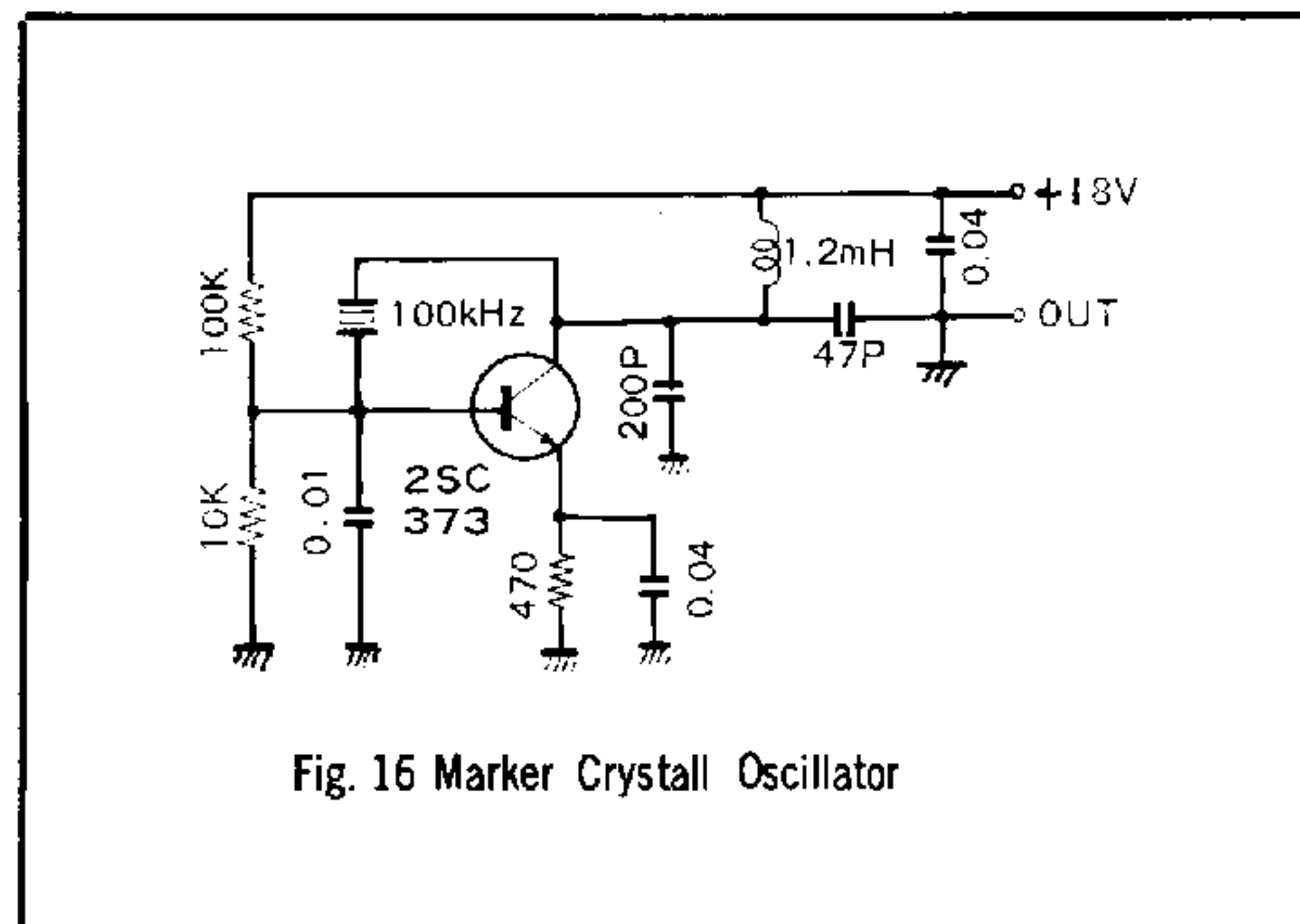

Fig. 16 Marker Crystall Oscillator

Thus, the carrier frequency of both lower and upper sidebands can be read on the dial.

The center frequency of SSB signals is always read at the red pointer. The receive frequency of CW signals can also be read in the same method as for LSB signals. The transmit frequency is always 800 Hz higher than the LSB carrier.

When the CW filter is used, this frequency relationship will change and transmit frequencies can be read at the red point. Receive frequencies can be read by the red pointer when the beat is 700 Hz and will be within ± 250 Hz at other best frequencies.

(5) Marker Crystal and Adjustments

The marker crystal is not provided and must be purchased separately. Its specifications are as follows.

Type: HC-13/U
Frequency: 100 kHz
Frequency tolerance: $\pm 0.003\%$
Specified oscillation circuit: See Fig. 16.

The marker oscillator circuit with this transceiver is already adjusted. The crystal will oscillate by merely setting the AGC/CAL knob to 25 kHz and inserting the crystal into the socket. However, it may oscillate at a frequency other than 25 kHz when the power source voltage fluctuates.

If this happens, adjust MULTI ADJ (VR701) located on printed circuit board UC1502J inside the chassis so that the oscillation is 25 kHz.

The 25 kHz multivibrator is synchronized with the 100 kHz crystal oscillator. Therefore, it is necessary to match the crystal oscillation to 100 kHz. This adjustment can be accomplished with the ceramic trimmer (TC701).

(6) Remote VFO

The Model VFO-5D is supplied by the manufacturer for use with the TS-510. This is externally connected to the transceiver.

Its major circuitry is identical to the internal VFO in the TS-510. The remote VFO enhances the versatility of the TS-510 when used in conjunction with the built-in VFO.

One of the added features is that the two VFO's enable the transceiver to serve as an independent receiver and transmitter. The external VFO permits any amount of separation when desiring to separate the receive and transmit frequencies, while the RIT, which also makes it possible to separate the frequencies, but permits only a slight value and within the same band. Either of the VFO's can be used for receive or transmission. This is extremely useful in actual operation.

The second feature is that the remote VFO can be controlled by a crystal, which finds use in such cases as joining a round QSO or calling or receiving a station on schedule where no frequency drift is allowed.

The third feature is that it permits reproduction of the frequency used in the previous QSO. This can be accomplished by turning the AGC/CAL switch to VFO, and taking a zero beat between the internal VFO and the remote VFO. Thus, either the remote or internal VFO can be set to the frequency, without any human error.

The remote VFO also contains an RIT circuit.

Calibration of the remote VFO with the built-in VFO can be accomplished by turning the AGC/CAL switch to VFO and the RF gain counterclockwise. A beat tone can be heard from the speaker as the frequencies of the two VFO's approach each other. This beat is a double beat produced by the two VFO's and can be immediately identified from the other type of beat, a signal beat. Adjust the dial until zero beat is obtained. This indicates that one VFO frequency is identical to the other. Transmission is impossible when the AGC/CAL switch is set to VFO.

(7) S-meter

The S-meter indicates S9 at an input of 40 dB and increases one graduation for every 3 dB. Zero point error can be adjusted in the following manner. Disconnect the antenna from the transceiver and turn the S-METER potentiometer at the rear of the chassis. Note that the pointer of the S-meter should not be set to the zero point of the S-graduations but to the zero point of the I_p scale. A diode is inserted to prevent reverse swinging of the pointer. Therefore, to take correct readings of signal strength, the point should be correctly set to the zero point of the I_p scale.

(8) RF Meter

The RF meter reads the transmitted RF voltage. Deflection may vary with the type of antenna used. Adjust with the RF METER potentiometer (located at the rear of the chassis) so that it does not swing off the scale even with the greatest swing among the bands.

(9) Adjustment of Bias Voltage

The necessity of adjusting the bias voltage arises

when the transmitting tubes are replaced. Adjustment can be accomplished by means of the BIAS potentiometer at the rear of the chassis.

To adjust, set the MODE switch to LSB or USB and disconnect the microphone from the jack. In this state, set I_p to 60 mA (or 30 mA per tube).

(10) Side Tone

The magnitude of the side tone varies with operating conditions and a comfortable magnitude may differ from individual to individual.

To adjust, use semifixed resistor S TONE LEVEL (VR401) on printed circuit board UC1304J (AF block).

(11) ALC Meter

The meter set to ALC may swing off the scale when the input is excessively large. With the meter pointer staying within the black zone indicated as ALC, distortion is minimum and so is splutter. A suppression of approximately 6 dB is obtained with the pointer at the maximum limit of ALC.

When the ALC meter goes beyond the black zone, the transmitted SSB signal will appear distorted. Therefore, it is necessary to keep the ALC meter within the zone during SSB transmission.

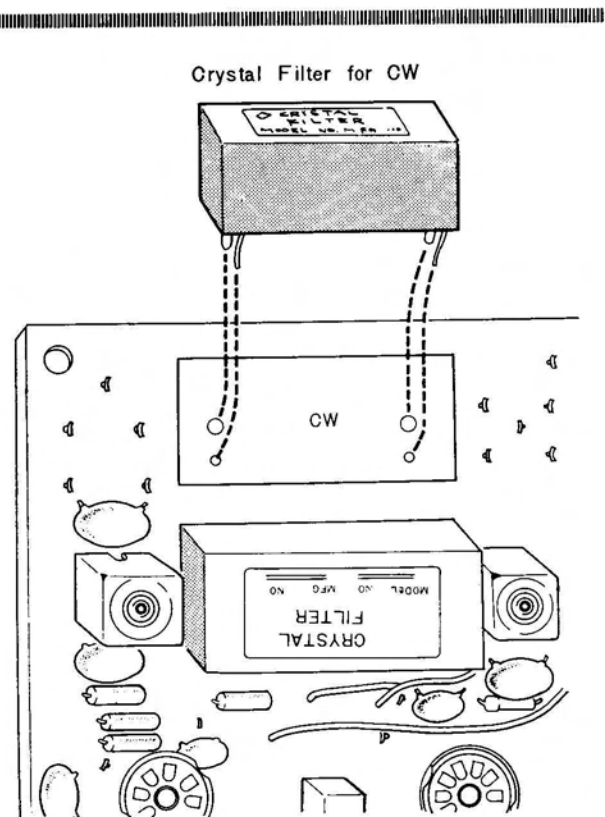

Fig. 17 Installing the CW Crystall Filter

ACCESSORIES CIRCUIT

1. INSTALLATION OF THE CW CRYSTAL FILTER

The CW crystal filter consists of

- | | |
|--------------------------|---|
| (1) Crystal filter | 1 |
| (2) Crystal (3395.0 kHz) | 1 |
| (3) Diode (1N60) | 4 |
| (4) Instruction manual | 1 |

(1) Installing the crystal filter

The SSB crystal filter is located on printed circuit board UC1204J (IF unit). There are four holes next to the SSB filter. Install the CW filter into these holes as shown in Fig. 17.

(2) Installing the crystal (3395.0 kHz)

Refer to Fig. 18 and install the crystal in the following manner. Look into the back of the chassis. There is a printed circuit board (UC1405J), which is the carrier oscillator unit, in the back of the output transformer. There are three crystals mounted on this printed circuit board. Remove crystal X002 (3394.3 kHz, housed in the crystal holder) and change it to the space holder (X004).

Insert the 3395.0 kHz crystal into socket X002.

Terminals XL and XCR are shunted with a 0.8 mm tinned jumper wire. Cut this jumper wire with a cutter.

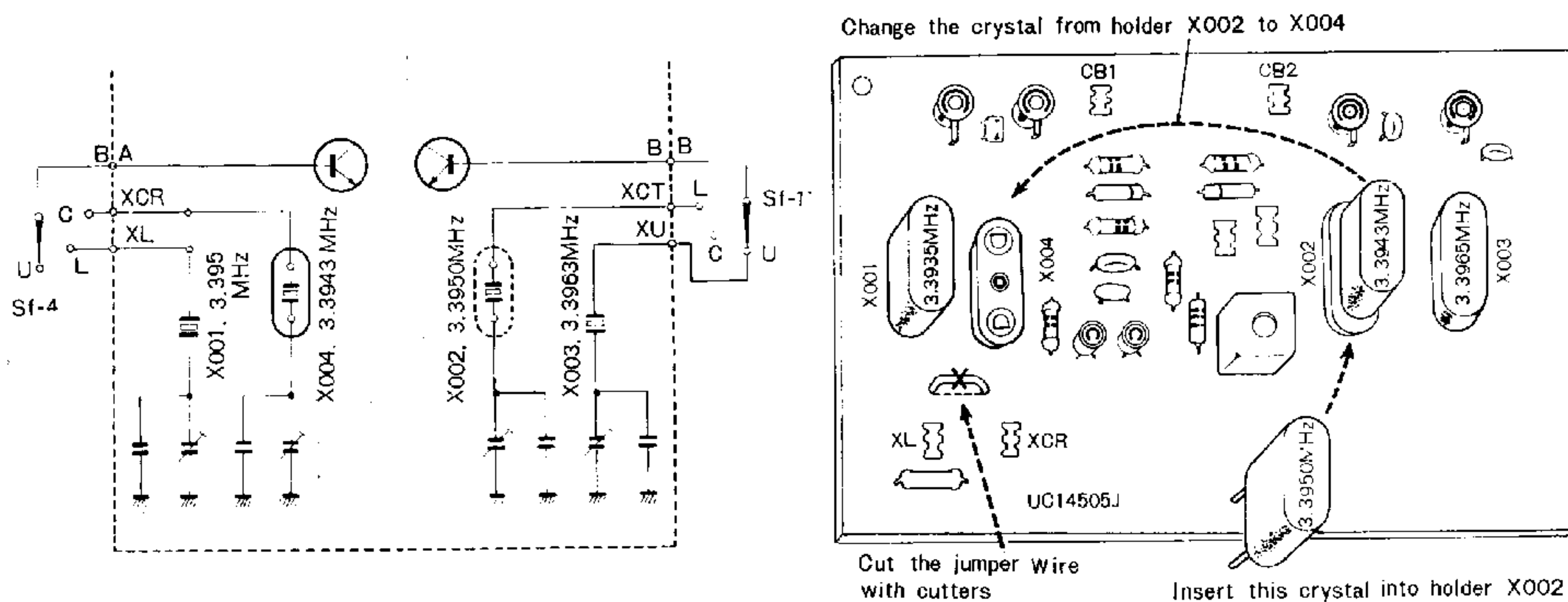

Fig. 18 Installing the crystal

(3) Installing Diodes (1N60 × 4)

Remove the four screws from the diode switch unit (UC1209J) located between the IF printed circuit board and the carrier oscillator printed circuit board, cut the two jumper wires at the places indicated in Fig. 19, and install the four diodes.

Do not remove the jumper wires with excessive force since this might damage the printed circuits or the board.

This completes the installation of the CW filter. Enjoy CW operation.

2. HOW TO USE THE EXT SWITCH

Remove the blank plate below designation EXT SW at the rear of the chassis.

Install double-pole double-throw slide switch in this hole, the same as the ANT SW.

This switch may be used in various ways. One example is to take the output of this transceiver for a 50 MHz converter from the REC ANT terminals. In this case, the final power tube circuit is switched open by this slide switch. The circuit is shown in Fig. 20.

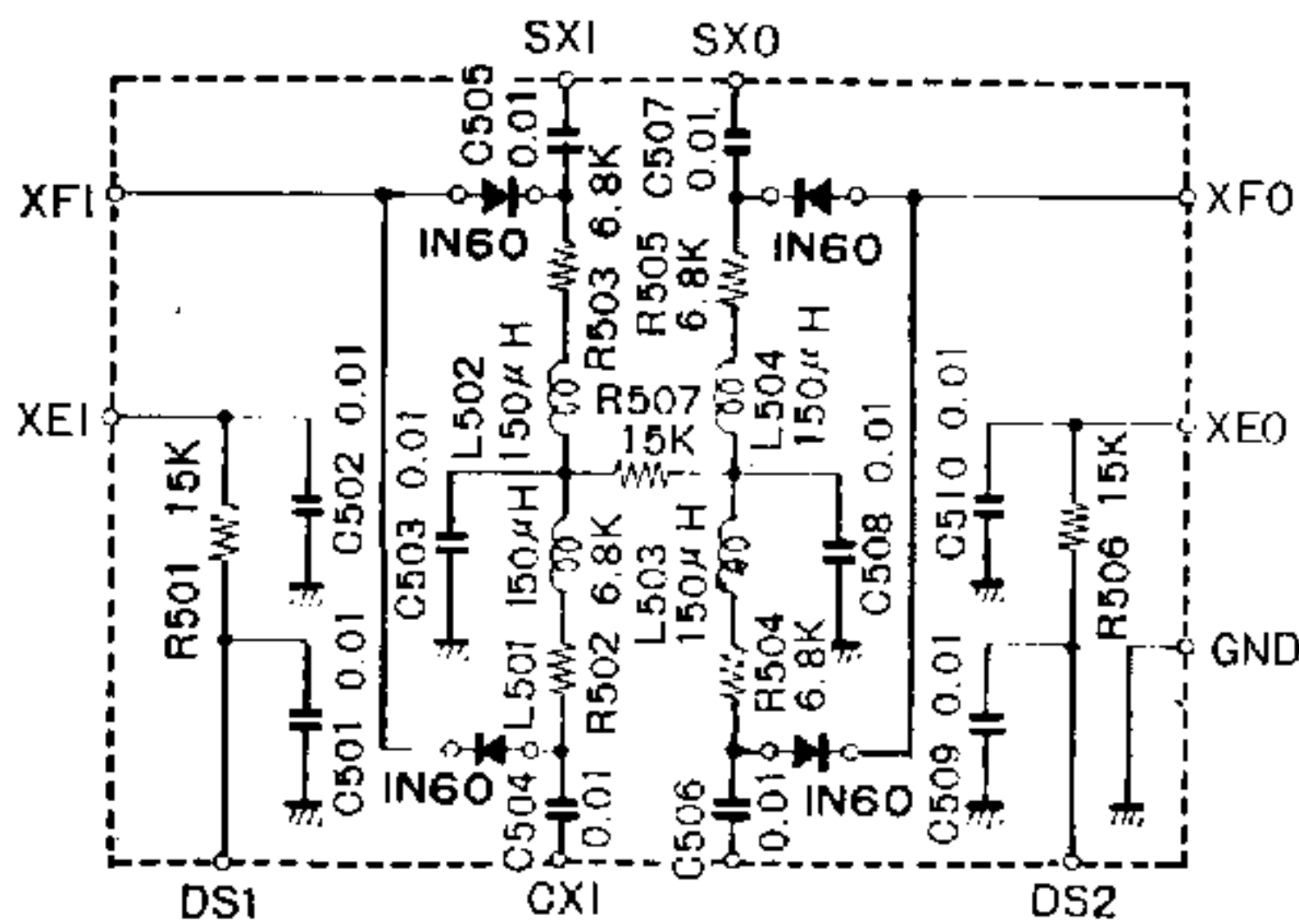
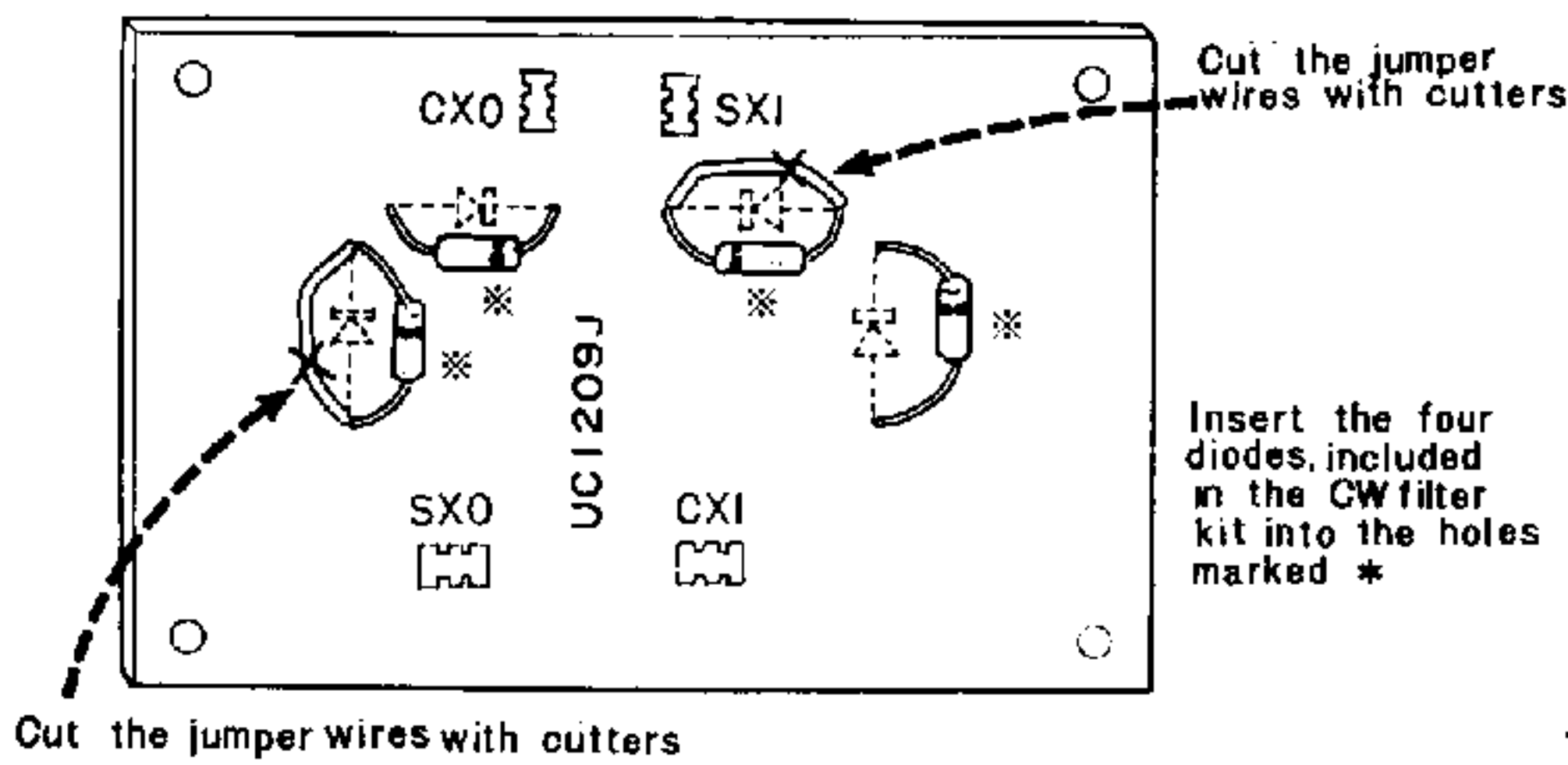

Fig. 19 Installing the diodes

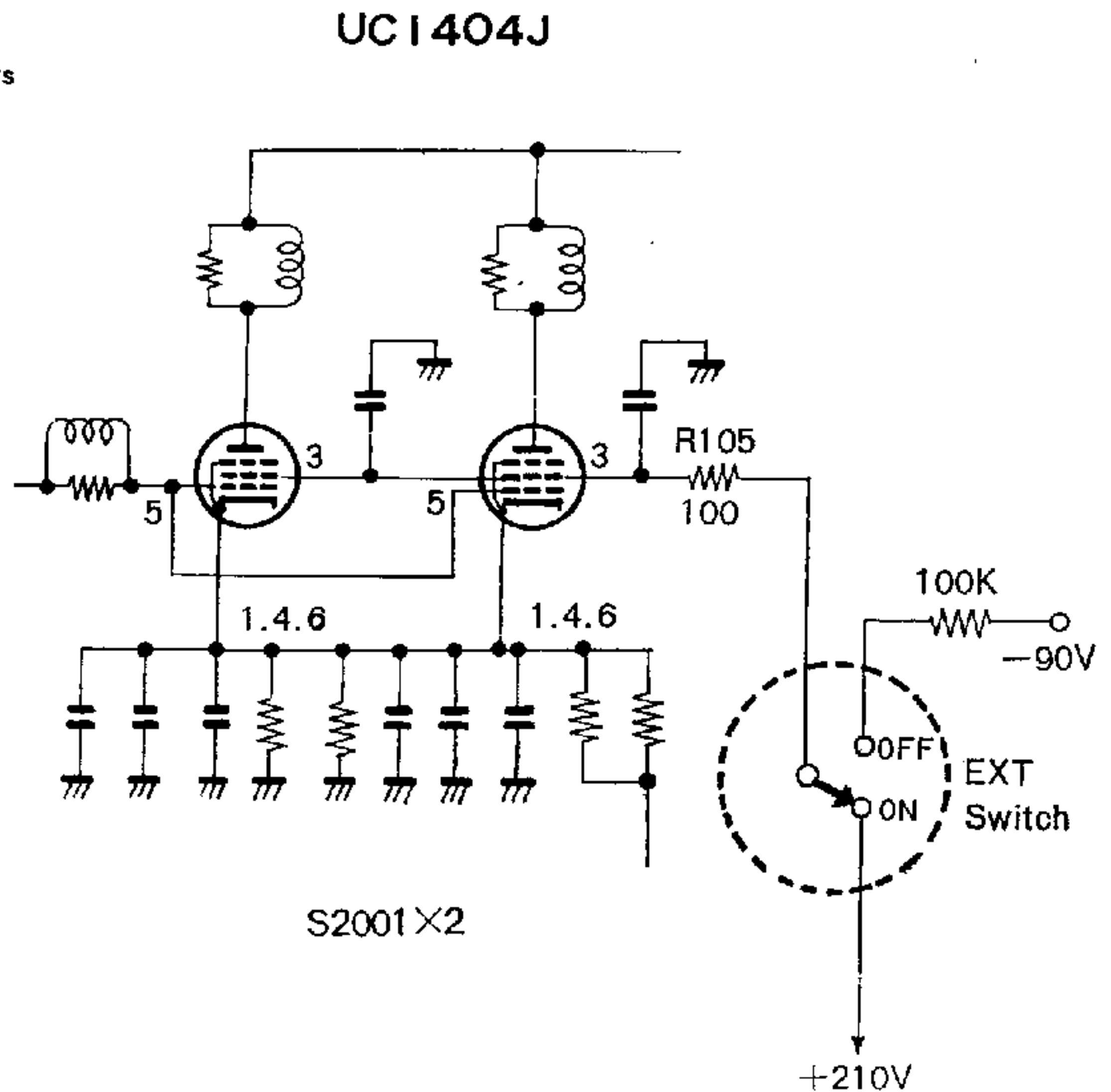

Fig. 20 Example use of the EXT switch

ALIGNMENT AND MAINTENANCE

Be Careful of High Voltages!

Some of the TS-510 circuits have extremely high voltages. Adequate precaution is required to avoid accidents.

The TS-510 is completely adjusted and requires no additional adjustments except that, after a long period of use, the tuning circuits may become misaligned. Readjustment should be made every two or three years. Thus, the transceiver can be maintained at its peak capability.

Table 4, lists the values of the DC voltages of the individual circuits operating under normal conditions. The use of a vacuum tube voltmeter with an input impedance of more than 5 MΩ is recommended for measurements of these circuits. Many good measuring instruments are required for good adjustments. However, here might be a limit to the kind and number of measuring instruments accessible to an individual. Therefore, adjusting methods which can be done with a simple multimeter are presented here. When adjustments prove to be beyond the capability of the available test equipment or difficult troubles occur, your repair shop will handle them for you at costs.

Table 4 Voltage at Individual Electrodes

(Vacuum tubes)

Pin No.		1	2	3	4	5	6	7	8	9	P
V101	T	1.05		200	Same as 1	-50	Same as 1				830
S 2001	R	0.05	(6.3)	210		-65		(12.6)			950
V102	T	1.05		200	Same as 1	-50	Same as 1				830
S 2001	R	0.05	(0)	210		-65		(6.3)			950
V201	T	0	-8	120	(12.6)	(6.3)	4.6	0	150	285	
6AW8A	R	0	-9	120			0	-28	150	300	
V202	T	3	0	0	(12.6)	(12.6)	(6.3)	290	150	0	
12BY7A	R	0	-29	0				300	150	0	
V203	T	-27	0	(6.3)	(12.6)	150	150	0			
6CB6	R	0	1.7			145	65	0			
V204	T	0	150	(0)	(6.3)	290	150	0			
6BZ6	R	0	1.1			300	80	0			
V301	T	-3.1	0	(6.3)	(12.6)	140	140	0.8			
6BA6	R	0	0			130	130	1.8			
V302	T	75	0	90	(12.6)	(6.3)	150	2.5	0.8	0	
6GH8A	R	230	-28	150		150	150	-19	7	0	
V303	T	-55	-27	(6.3)	(0)	150	150	0			
6CB6	R	0	2			150	85	0			
V304	T	0	0	(0)	(6.3)	150	150	230			
6BA6	R	0	0			130	130	1.3			
V401	T	50	14.0	0	(6.3)	(0)	200	200	0	150	
6BM8	R	0	14.0	0			220	207	1.3	90	
V601	T	150	0	13	(0)	(6.3)	27	0.5	48	30	
6GH8A	R	150	0	13			47	0.5	48	30	
V602	T	-3	0	(12.6)	(6.3)	150	140	6			
6BA6	R	0	0			150	150	39			
V603	T	150	0	45	(6.3)	(0)	60	1.3	3.5	0	
6GH8A	R	150	0	45			60	1.3	0	-29	

(Transistors)

		E	C	B
Q101	T	-50	-4	-50
2SC856	R	-65	0	-65
Q001	T	0	18	-9
C373	R	3	18	3.2
Q002	T	2.9	18	+3.2
C373	R	0	18	-2.8
Q301	T	0.85	18	1.4
C373	R			
Q302	T	-27	-0.12	-28
C373	R			
Q401	T	0.35	10.5	0.9
C373	R			
Q701	T	0.25	18	0.85
C373	R			
Q702	T	0	2.3	-1.0
C373	R			
Q703	T	0	8.1	-2.8
C373	R			
Q704	T	0	4.0	-1.5
C373	R			

1. * (A): MODE switch - CW

* (B): AGC/CAL switch - 25kHz

T: At maximum transmit power

R: In the absence of receive signals

(): Indicates AC voltages

Such units as the VFO, crystal filter, BPF, etc., require elaborate knowledge and technique to adjust, and malfunction resulting from careless adjustments will not be taken care of by the manufacturer.

1. RECEIVER SECTION

(1) Carrier oscillator (UC1405J) Refer to Fig. 21.

Adjustments of this unit are those of the oscillation (BFO) and frequency. Slowly turn the slug of the oscillation transformer (T001) clockwise. The oscillation will stop as it is turned. This is known from that the internal operating noise disappears. Back up about one half of a turn to the point where oscillation starts. Carry out this adjustment at LSB.

Oscillation frequency adjustment is made with the trimmer (TC002, 003, and 004) inserted in series with the crystal. For accurate adjustment, a frequency counter is required. However, adjustment may be made with a stable signal generator or marker oscillator and by once setting the s-meter to a deflection of S9 and then turning the dial back to a meter indication of S2, at which point the trimmer (TC003 and 004) should be adjusted to obtain a zero beat.

The 3393.5 kHz and 3396.5 kHz crystals can also be adjusted by the above method when the CW filter is used. Receive a 3394.3 kHz signal with a maximum deflection of the s-meter, and adjust TC001 so that the beat is 700 ~ 800 Hz. For 3395.0 kHz, adjust TC002 in the CW mode so that driving power is maximum. The above adjustments will be proper if the trimmers are all half meshed.

(2) IF stage (UC1204J) Refer to Fig. 22.

This unit has four large IFT's and four small IFT's. Two IFT's (L301 and L308) for the crystal filter small IFT's (L304, L305, L306, and L307) need not be adjusted.

Receive a stable signal and adjust the cores of L303 and L309 slowly with the accessory hex screwdriver so that the s-meter reads maximum deflection. L303 is a dual tuned type and is adjusted at the top and bottom of the chassis.

(3) Heterodyne crystal oscillator (UC1110J) Refer to Fig. 23.

Adjust the core of the crystal oscillator nearest the panel in the coil pack.

Use the hex screwdriver to turn the core. Set the screwdriver perpendicular to avoid damaging the core which breaks easily.

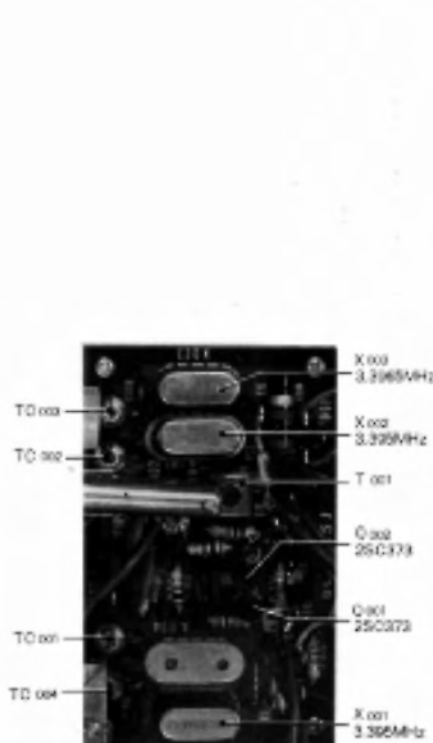

Fig. 21 Carrier Unit

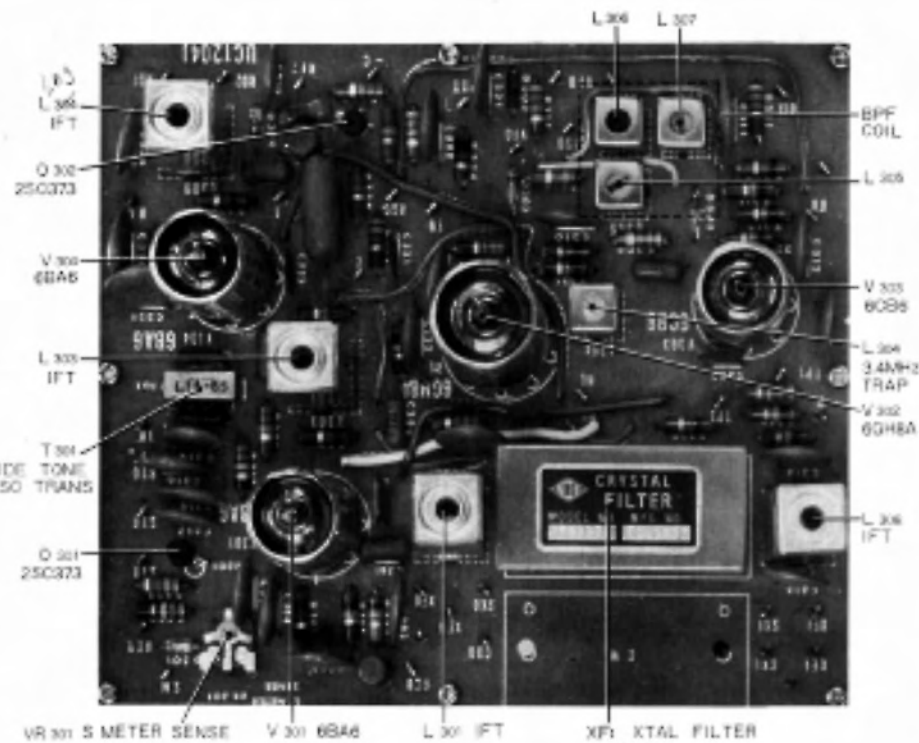

Fig. 22 IF Block

The oscillation will stop as the core is turned clockwise. Stoppage is known from disappearance of the internal noise. Back up the core about one half of a rotation to the point where oscillation starts. Oscillation will be unstable if the core is set to a point close to a critical point of oscillation.

Conduct the same adjustment for all the bands. In the 28 MHz band, adjust only the 28 MHz band. The 28.5 MHz and 29.1 MHz bands need not be adjusted.

The coil pack cover need not be removed during this adjustment.

(4) Drive (RF) tuning circuit (UC1108J and 1109J) Refer to Fig. 23.

The drive grid tuning core is located in the center of the coil pack. The drive plate tuning core is on the final power tube side. Receive a stable signal (of a marker, signal generator, etc.) at the center of the bands (3.75 MHz, 7.15 MHz, 14.175 MHz, 21.225 MHz, and 28.8 MHz), and set the drive variable capacitor to the 12 o'clock position. Switch the band switch to 3.5, 28, 21, 14, and then to 7 MHz while observing the s-meter. Adjust the core of the drive plate and drive grid coils.

The coils of this stage are connected in series and parallel. Set the frequencies to within ± 25 kHz. Otherwise, all bands cannot be tuned.

The cores are fragile. Do not apply excessively force, and set the tool perpendicularly on the core to avoid breakage.

(5) 8.6 MHz Trap

This coil is laid on its side between the coil pack and the final power tubes.

Connect a strong signal (greater than 100 dB/ μ V) with a frequency of 8.6 MHz to the antenna terminals, receive it at about 14.3 MHz to produce a beat with it, and adjust the core so that the beat is minimized.

2. TRANSMITTER SECTION

(1) Carrier balance and carrier level (UC1501J) Refer to Fig. 24.

Connect a dummy load to the antenna terminal, turn the knob with the transceiver set to the 14 MHz band, and tune the individual stages. This adjustment should be carried out quickly and completed before the plate of the S2001 tubes are heated red.

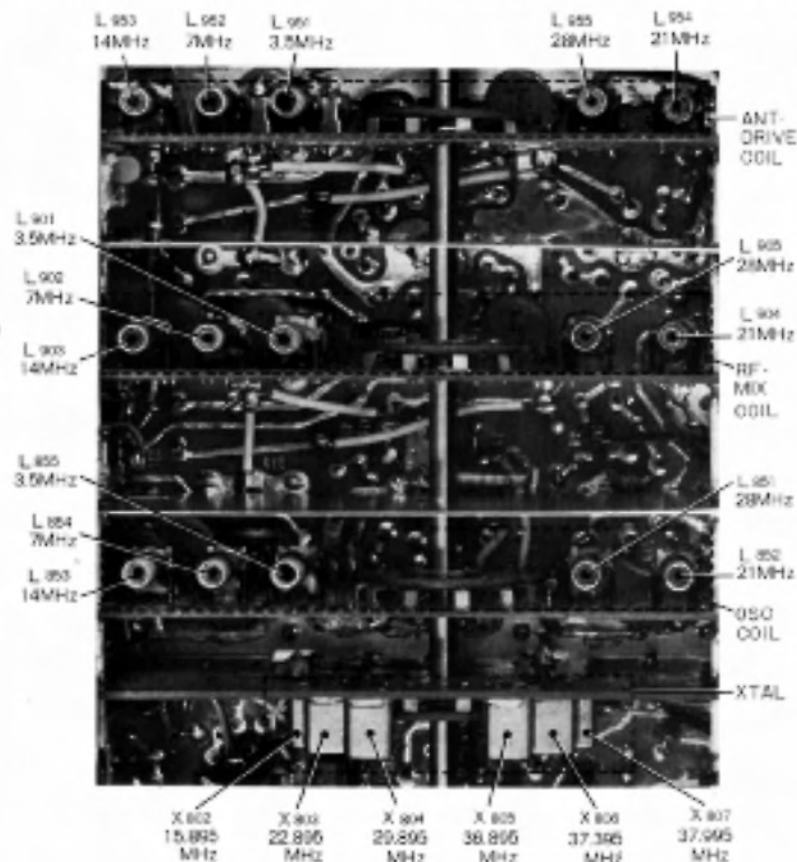

Fig. 23 Coil Pack

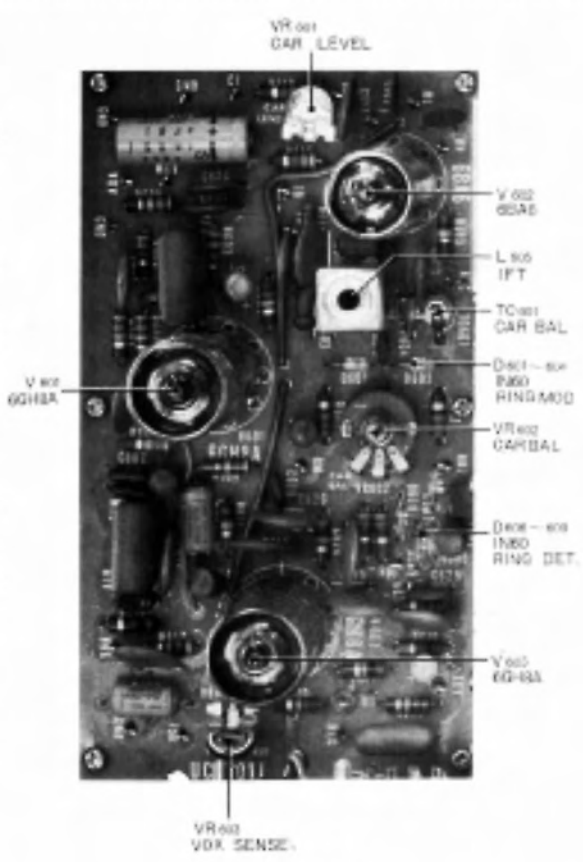

Fig. 24 BM Block



Now adjust the carrier level adjust VR (VR601) on the BM block so that the ALC voltage becomes approximately 200 mA on the Ip scale.

Switch the MODE to LSB and set the RF voltmeter to its maximum sensitivity. The voltmeter will deflect if the circuit is out of balance. The MIC GAIN VR should be set to its minimum value during this adjustment.

To balance the carrier, alternately adjust the trimmers (TC601) and VR (VR602) on the BM block. Then switch the MODE to USB and readjust so that the same amount of carrier suppression is obtained at both LSB and USB.

(2) Neutralization of final power amplifier stage

Tune the driving and final power stages with the MODE set to CW (28 MHz).

Remove the voltage from the screen grid and anode of the S2001 tubes, and measure the output at the antenna terminal with a high sensitivity voltmeter. Adjust the neutralizing capacitor (TC1, attached to the final power tube shielding box) so that the output is minimized. A receiver which is capable of receiving the 28 MHz band can be used in place of a high sensitivity voltmeter.

Remove the high voltage from the screen grid and anode before disconnecting the wiring.

3. TROUBLES RESULTING FROM MALADJUSTMENT

(1) Carrier oscillator

The transmit output will not be delivered when the oscillation stops. Nor is a beat produced during reception. Therefore, SSB and CW cannot be received.

Carrier frequency changes may result in a double beat, higher reproduced SSB tone, or reduced output if the CW filter is used but not tuned exactly to 3395.0 kHz.

(2) IF stage and coil pack

Receive sensitivity and transmit output drop. Malfunctioning of the crystal heterodyne oscillator makes transmit driving and reception of the amateur bands impossible.

(3) 8.6 MHz trap

Trouble appears as interference in the receive 1st IF frequency (8.895 ~ 8.295 MHz) at the 7 MHz band.

(4) Carrier balance

The RF voltmeter does not return to the zero position even in the absence of an SSB signal. This can be observed when all the stages are finely tuned and the set is in the CW mode. If this signal is received the carrier cannot be received.

(5) Neutralization of the final stage

Abnormal oscillation occurs at the final tubes, Ip current of greater than 60 mA flows in the absence of SSB input, or the SSB signal is distorted, resulting in increased splutter.

(6) VOX

Relay do not operate even in the presence of an AF input, do not open in the absence of an RF input, or operation is delayed.

(7) RIT

Tuning the transmit frequency to that of the associated station becomes impossible.

(8) Balance with the final stage

The plate dissipation of the S2001 tubes increases and the service life of the tubes is shortened or distortion and hence splutter increases.

(9) S-meter

If the zero point is on the negative side of the scale, deflection will become sluggish or in the worst case it does not deflect at all.

(10) Drop power source voltage

Receive sensitivity and transmit output decrease. Caution is necessary when there are large line voltage fluctuations.

Voltage drop of the 150 V line of the voltage regulated power supply in the PS-510 also appears as the identical trouble. When it goes higher, the service life of the vacuum tubes will be reduced.

4. MAINTENANCE

(1) Removal of the case

Top cover: The top cover can be removed in the upward direction by removing the two black screws on top and the four large and small decorative screws on each (right and Left) side.

Bottom cover: The bottom cover can be removed by removing the nine screws from the bottom of the chassis. The Hyzex legs need not be removed, as they are not connected to the chassis.

A Phillips screwdriver must be used to remove the screws, while a coil may be used for the decorative screws.

Prepare a container in which the (removed) screws may be kept, to avoid misplacement.

(2) Vacuum tubes and transistors

Do not use the S2001 tubes under a voltage of higher than 1000 volts or under detuned conditions since this will increase plate dissipation beyond the rated value and hence reduce their service life.

When replacing vacuum tubes, use a tube from the same manufacturer, if possible.

Avoid use of a second hand tubes, which might result in unexpected troubles.

Even the simplest shortage in the printed circuits can damage the transistors. Take adequate care when checking on them.

(3) Resistors and capacitors

Resistors, when defective, may be replaced with those having a value of $\pm 10\%$. For example, a 330Ω resistor may be replaced with a 300Ω resistor.

The same applies to replacement of capacitors, except for consideration of their working voltage.

Capacitors used with the vacuum tubes are almost always 500 WV unless otherwise indicated.

(4) Dial gear

Apply machine oil to the dial gears and bearings after removing any dust. Lubrication interval is once a year.

(5) Pilot lamps

There are two pilot lamps with a voltage rating of 15V. Use a swan base type.

(6) Dirt and dust

The knobs will be come oxidized or contaminated with fingerprints after long use. Remove them and clean with a neutral cleaner. Cleaning will add to the operating pleasure.

The panel is exposed to dust and dirt and has minute corrugations, which collect dust. Clean it with a piece of soft cloth.

The interior also accumulates dust over a period of time. Dust is a good media to impair insulation, causing troubles. Remove it with an electric cleaner every six months.

(7) Troubles

There is no limit to the type of troubles. A visit your dealers for correction of troubles, especially in the VFO, BPF, or crystal filters, whenever they prove to be beyond the coverage of the instruction book is recommended.

BE CAREFUL OF THE HIGH VOLTAGES !

The S2001 power tubes normally have a voltage of higher than 800V. When checking the interior of the final tube shield box for example, be sure to remove the high voltage by disconnecting the power plug and discharging the residual voltage by shunting with a screwdriver, etc.

BE CAREFUL OF THE HIGH VOLTAGES !

CHASSIS TOP VIEW

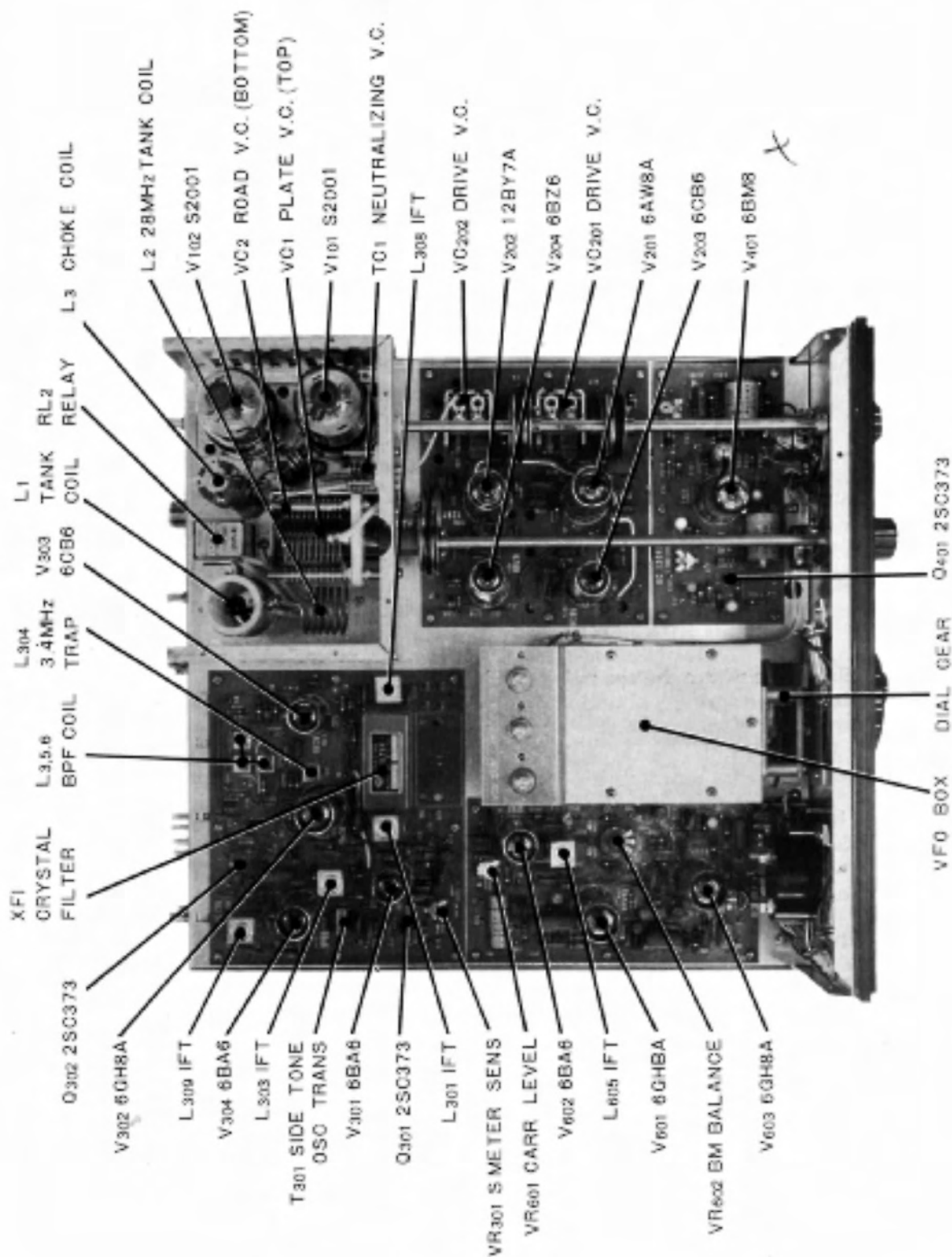

CHASSIS BOTTOM VIEW

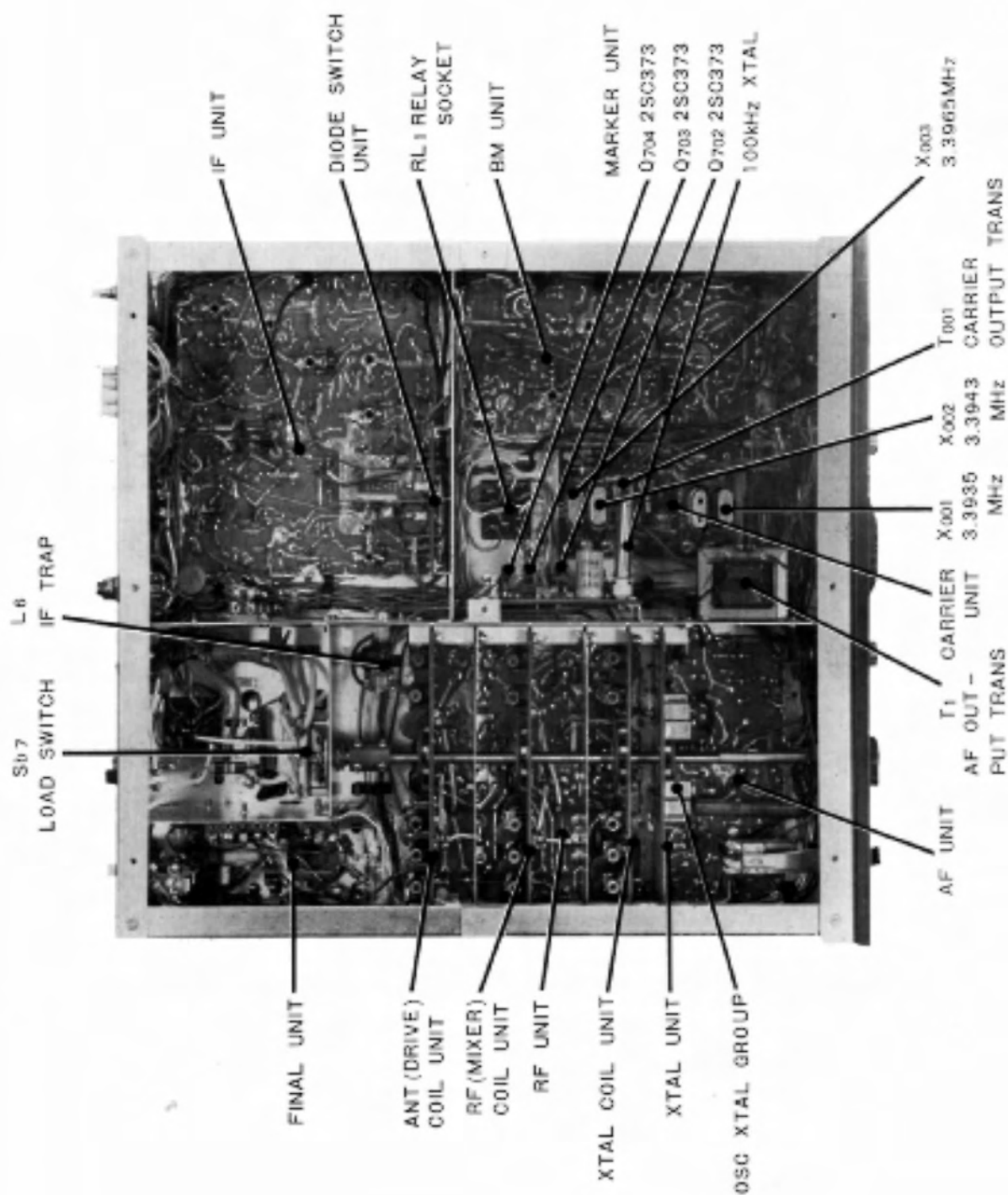

SPECIFICATIONS

RECEIVE AND TRANSMIT FREQUENCIES:	80 meter band 3.5 ~ 4.000 MHz 40 meter band 7.0 ~ 7.300 MHz 20 meter band 14.0 ~ 14.35 MHz 15 meter band 21.0 ~ 21.45 MHz 10 meter band A 28.0 ~ 28.5 MHz B 28.5 ~ 29.1 MHz C 29.1 ~ 29.7 MHz
TYPE OF EMISSION:	SSB (A3J), CW (A1)
RATED INPUT TO FINAL STAGE:	160 W at 3.5 ~ 21 MHz 120 W at 28 MHz
ANTENNA INPUT IMPEDANCE:	50 ~ 75 Ω
CARRIER SUPPRESSION:	Less than -40 dB
SIDEBAND SUPPRESSION:	Less than -40 dB
MICROPHONE IMPEDANCE:	50 K Ω (high impedance)
TRANSMIT FREQUENCY CHARACTERISTIC:	300 ~ 2700 Hz (-6 dB)
RADIATION OF UNWANTED COMPONENTS:	Less than -50 dB
RECEIVE SENSITIVITY:	0.5 μ V, S/N ratio of 10 dB at 3.5 ~ 21 MHz 1.5 μ V, S/N ratio of 10 dB at 28 MHz
IMAGE RATIO:	More than 50 dB
IF INTERFERENCE:	More than 50 dB
FREQUENCY STABILITY:	Within +2 kHz 60 minutes after the power switch is turned on. Within 100 Hz after 30 minutes.
SELECTIVITY:	SSB: More than ± 1.2 kHz (at -6 dB) Less than ± 2.4 kHz (at -60 dB) CW: More than ± 250 Hz (-6 dB) Less than ± 750 Hz (at -60 dB) Note: Selectivity values in the CW mode applies to a transceiver with the CW filter used.
AF OUTPUT:	More than 1 watts (with 10% distortion)
RECEIVER OUTPUT IMPEDANCE:	8 Ω for both speaker and headphones
POWER CONSUMPTION:	315 watts at maximum output of reception (When the PS-510 is used)
VACUUM TUBES AND TRANSISTORS:	14 vacuum tubes, 2 FET's, 13 transistors, and 29 diodes
DIMENSIONS:	330 (W) \times 180 (H) \times 345 (D) mm (13" W, 7" H, 13 $\frac{5}{8}$ " D)
WEIGHT:	9.5 kg (20.9 lbs)

SCHEMATIC DIAGRAM

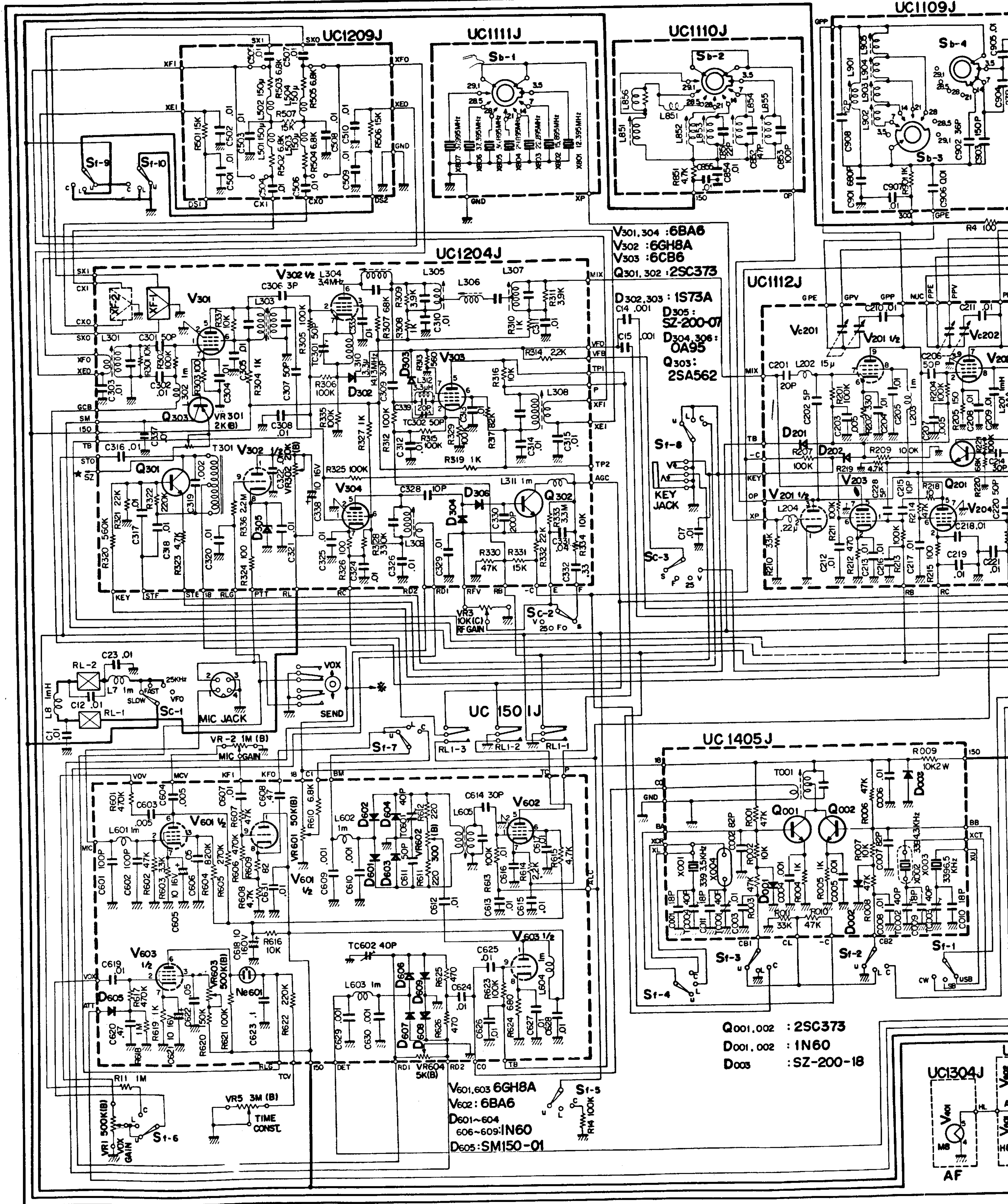

SCHEMATIC DIAGRAM

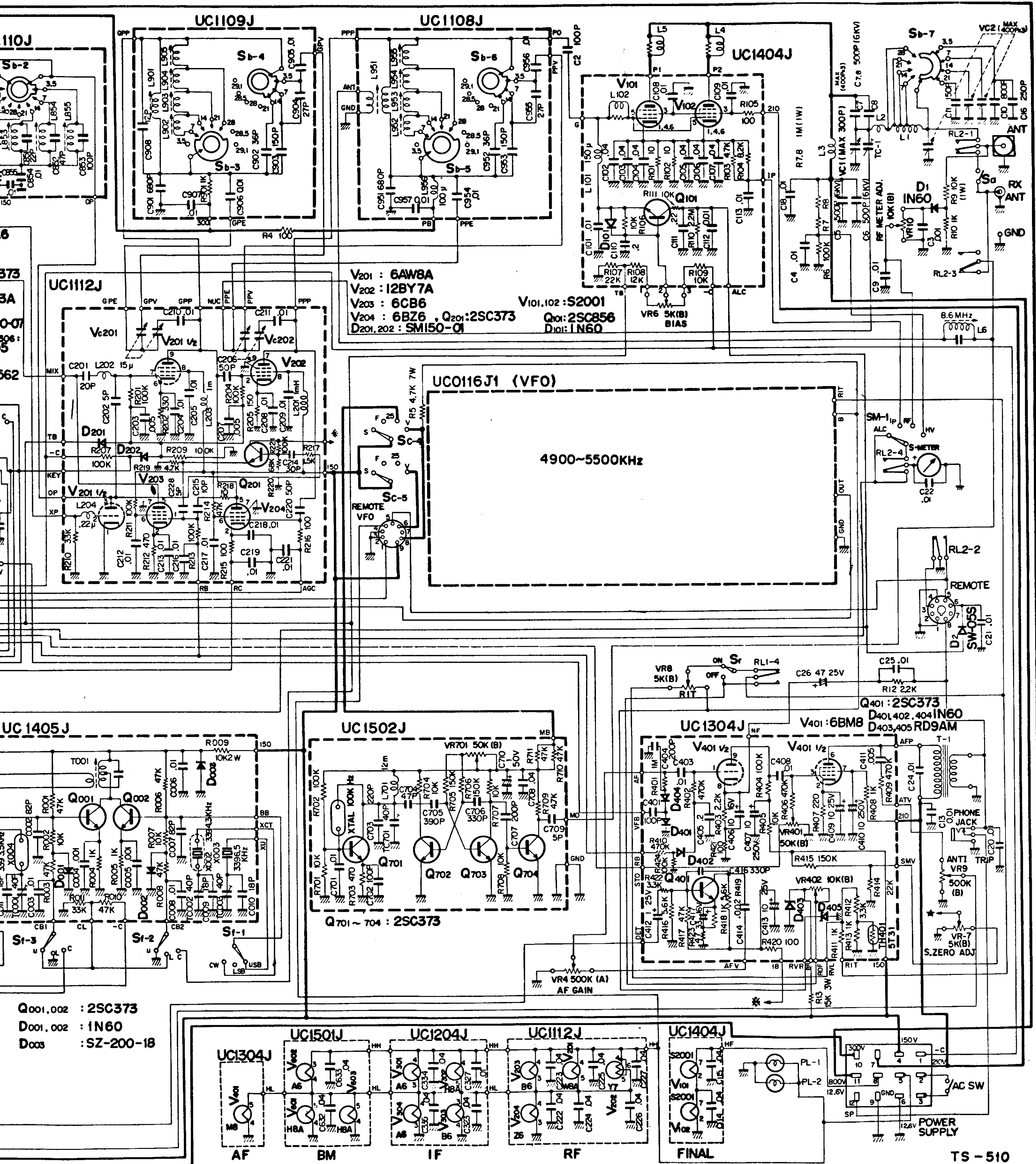

V201 : 6AW8A
V202 : 12BY7A
V203 : 6CB6
V204 : 6BZ6
D201, 202 : SMI50-OI
V101, 102 : S2001
Q101 : 2SC856
D101 : 1N60

UC0116J1 (VFO)
4900~5500kHz

Q001, 002 : 2SC373
D001, 002 : 1N60
D003 : SZ-200-18

K4XL's **BAMA**

This manual is provided **FREE OF CHARGE** from the “BoatAnchor Manual Archive” as a service to the Boatanchor community.

It was uploaded by someone who wanted to help you repair and maintain your equipment.

If you paid anyone other than BAMA for this manual, you paid someone who is making a profit from the free labor of others without asking their permission.

You may pass on copies of this manual to anyone who needs it. But do it without charge.

Thousands of files are available without charge from BAMA. Visit us at <http://bama.sbc.edu>